

INSTRUCTION MANUAL

7016

SIGNAL SOURCE

HIOKI E. E. CORPORATION

Contents

Introduction	1
Verifying Package Contents	1
Safety Information	3
Operating Precautions	6
1 Overview	9
1.1 Product Overview	9
1.2 Features	10
1.3 Names of Parts	11
1.4 Display (LCD)	14
1.5 Sourcing and Measurement Procedures	18
2 Preparations	19
2.1 Connecting the AC Adapter	19
2.2 Charging the Internal Batteries	20
2.3 Connecting the Test Leads	21
2.3.1 Connections	22
2.4 Turning Power On / Off	23
2.5 Function Selection	24
2.5.1 Source Function Settings	24
2.5.2 Measurement Function Settings	28
3 Using Source Functions	31
3.1 Constant-Voltage Source (DCCV)	32
3.2 Constant-Current Source (DCCC)	35
3.3 Pulse Source (PULSE)	37
3.4 Using Memory Function (SCAN and RAMP)	39
3.4.1 Using the SCAN Function	40
3.4.2 Using the RAMP Function	45

4 Using Measurement Functions 51

4.1	Measuring Voltage	52
4.2	Measuring Current	54
4.3	Measuring Frequency	56
4.4	Measuring Resistance	57
4.4.1	Continuity Test	58
4.5	Diode Test	59
4.6	Measuring Temperature	60
4.7	Source and Measure Simultaneously	61
4.8	Special Measurement Functions	62
4.8.1	Recording Function	63
4.8.2	Data Hold / Refresh Hold Function	66
4.8.3	Relative (relative display) Function	67
4.8.4	1-ms Peak Hold Function	68
4.8.5	Dual Display Function	70

5 Functions 73

5.1	Auto Power Off Function	73
5.2	Backlight Function	74
5.3	RS-232C Communication Functions	75
5.4	Power-On Options	76

6 Applications 79

6.1	Transducer Calibration	79
6.2	Loop Test	81

7 Specifications 85

7.1	Product Specifications	85
7.2	Accuracy	88
7.2.1	Source Range and Accuracy	88
7.2.2	Measurement Range and Accuracy	89

8 Maintenance and Service 95

8.1	Replacing the Batteries	96
8.2	Replacing the Fuses	98
8.3	Before returning for repair	99
8.4	Discarding the Instrument	100
8.5	Cleaning	100



Introduction

Thank you for purchasing the HIOKI "Model 7016 SIGNAL SOURCE." To obtain maximum performance from the instrument, please read this manual first, and keep it handy for future reference.

Verifying Package Contents

When you receive the instrument, inspect it carefully to ensure that no damage occurred during shipping. In particular, check the accessories, panel switches, and connectors. If damage is evident, or if it fails to operate according to the specifications, contact your dealer or Hioki representative.

◆ Instrument

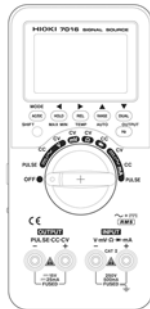

7016 SIGNAL SOURCE

◆ Accessories



3851-10 TEST LEAD (one each red and black, for input terminal)..... 1



Test leads (one each red and black, for output terminal) 1



Test lead (Yellow, with 15-V zener diode) 1

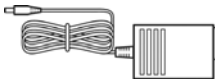

AC Adapter (SA-141A0F-11) (with power cord)..... 1

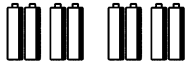
Verifying Package Contents

Battery pack (Ni-MH battery, installed) 8



Alligator clips (one each red and black, for Model 3851-10) 1



Connection band 1

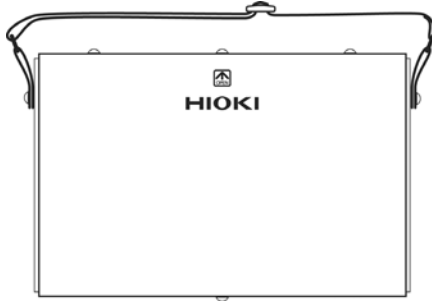

Carrying Case 1



Instruction manual



Operation manual

The supplied battery pack (Ni-MH battery, installed) is not charged when shipped from the factory. Charge it using the supplied AC adapter.

❖ 2.2 "Charging the Internal Batteries" (20 p.)









Safety Information







This instrument is designed to comply with IEC 61010 Safety Standards, and has been thoroughly tested for safety prior to shipment. However, mishandling during use could result in injury or death, as well as damage to the instrument. Be certain that you understand the instructions and precautions in the manual before use. We disclaim any responsibility for accidents or injuries not resulting directly from instrument defects.

Safety Symbols

This manual contains information and warnings essential for safe operation of the instrument and for maintaining it in safe operating condition. Before using it, be sure to carefully read the following safety precautions.

	In the manual, the  symbol indicates particularly important information that the user should read before using the instrument.
	The  symbol printed on the instrument indicates that the user should refer to a corresponding topic in the manual (marked with the  symbol) before using the relevant function.
	Indicates a grounding terminal.
	Indicates a double-insulated device.
	Indicates DC (Direct Current).
	Indicates AC (Alternating Current).

The following symbols in this manual indicate the relative importance of cautions and warnings.

	Indicates that incorrect operation presents an extreme hazard that could result in serious injury or death to the user.
	Indicates that incorrect operation presents a significant hazard that could result in serious injury or death to the user.
	Indicates that incorrect operation presents a possibility of injury to the user or damage to the instrument.
	Indicates advisory items related to performance or correct operation of the instrument.

Other Symbols

❖	Indicates the reference.
*	Indicates that descriptive information is provided bellow.
	Indicates quick references for operation and remedies for trouble-shooting.

Measurement categories (Overvoltage categories)

This instrument complies with CAT II safety requirements. To ensure safe operation of measurement instruments, IEC 61010 establishes safety standards for various electrical environments, categorized as CAT I to CAT IV, and called measurement categories. These are defined as follows.

CAT I	Secondary electrical circuits connected to an AC electrical outlet through a transformer or similar device.
CAT II	Primary electrical circuits in equipment connected to an AC electrical outlet by a power cord (portable tools, household appliances, etc.)
CAT III	Primary electrical circuits of heavy equipment (fixed installations) connected directly to the distribution panel, and feeders from the distribution panel to outlets.
CAT IV	The circuit from the service drop to the service entrance, and to the power meter and primary overcurrent protection device (distribution panel).

Higher-numbered categories correspond to electrical environments with greater momentary energy. So a measurement device designed for CAT III environments can endure greater momentary energy than a device designed for CAT II.

Using a measurement instrument in an environment designated with a higher-numbered category than that for which the instrument is rated could result in a severe accident, and must be carefully avoided.

Never use a CAT I measuring instrument in CAT II, III, or IV environments.

The measurement categories comply with the Overvoltage Categories of the IEC60664 Standards.

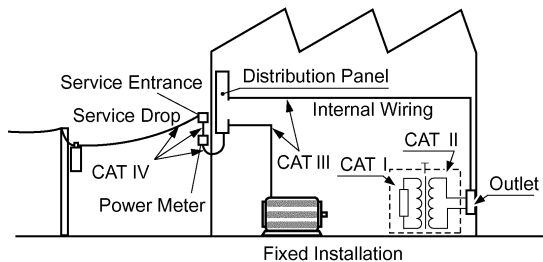

Accuracy

We define measurement tolerances in terms of f.s. (full scale), rdg. (reading) and dgt. (digit) values, with the following meanings:

f.s. (maximum display value or scale length)	The maximum displayable value or scale length. This is usually the name of the currently selected range.
rdg. (reading or displayed value)	The value currently being measured and indicated on the measuring instrument.
dgt. (resolution)	The smallest displayable unit on a digital measuring instrument, i.e., the input value that causes the digital display to show a "1" as the least-significant digit.

Operating Precautions



Follow these precautions to ensure safe operation and to obtain the full benefits of the various functions.

DANGER

- Before connecting the test leads, check the position of the function selector. Applying voltage when a non-voltage measuring range is selected may cause bodily injury and damage to the meter. Also, remove the test leads from the device under test before switching the function selector.
- Never apply voltage to the test leads when the Resistance Measurement (OHM), Current Measurement (DCA, ACA, ACDC), Continuity or Diode Test are selected. Doing so may damage the instrument and result in personal injury. To avoid electrical accidents, remove power from the circuit before measuring.

WARNING

- Use only the supplied AC Adapter (SA-141A0F-11). AC Adapter input voltage range is 100 to 240 VAC (with $\pm 10\%$ stability) at 50/60 Hz. To avoid electrical hazards and damage to the instrument, do not apply voltage outside of this range.
- To avoid the possibility of electric shock, always connect the green wire from the AC Adapter to ground.
- Do not use an AC Adapter other than the one supplied. Doing so could cause damage to the meter or other electrical mishap.
- Do not use the supplied AC Adapter with another device. It could damage the device or cause another electrical mishap.
- When replacing the batteries, do not mix old and new batteries, or different types of batteries. Also, be careful to observe battery polarity during installation. Otherwise, poor performance or damage from battery leakage could result.
- Do not allow the instrument to get wet, and do not take measurements with wet hands. This may cause an electric shock.
- Do not apply voltage or current exceeding the measurement range of each terminal. Hioki cannot take responsibility for accidents involving electric shock or insulation failures that could occur as a result of exceeding the specified range limitations.

CAUTION

- This instrument is designed for use indoors. It can be operated at temperatures between 0 and 40°C without degrading safety.
- Calibration and repair of this instrument should be performed only under the supervision of qualified technicians knowledgeable about the dangers involved.
- If the protective functions of the instrument are damaged, either remove it from service or mark it clearly so that others do not use it inadvertently.
- Do not store or use the instrument where it could be exposed to direct sunlight, high temperature or humidity, or condensation. Under such conditions, the instrument may be damaged and insulation may deteriorate so that it no longer meets specifications.
- This instrument is not designed to be entirely water- or dust-proof. Do not use it in an especially dusty environment, nor where it might be splashed with liquid. This may cause damage.
- For safety reasons, when taking measurements, only use the 3851-10 provided with the instrument.
- To avoid damage to the instrument, protect it from physical shock when transporting and handling. Be especially careful to avoid physical shock from dropping.

NOTE

- To avoid corrosion from battery leakage, remove the batteries from the instrument if it is to be stored for a long time.
- Because the input and output terminals are isolated from each other, signal source and DMM functions can operate simultaneously as two roles of the single instrument.
- Data can be transferred to a PC using the Model 3856-01 COMMUNICATION PACKAGE (RS-232C) or 3856-02 COMMUNICATION PACKAGE (USB).
- Correct source and measurement may be impossible in the presence of strong magnetic fields, such as near transformers and high-current conductors, or in the presence of strong electromagnetic fields such as near radio transmitters.

Before Use

Before using the instrument the first time, verify that it operates normally to ensure that no damage occurred during storage or shipping. If you find any damage, contact your dealer or Hioki representative.



Before using the instrument, make sure that the insulation on the test leads is undamaged and that no bare conductors are improperly exposed. Using the product in such conditions could cause an electric shock, so contact your dealer or Hioki representative for replacements. (Model 3851-10)

Pre-Operation Inspection

Before using the instrument, verify that the instrument operates normally to ensure that the no damage.

Overview

1

1.1 Product Overview

- ◆ **Handy multi-function calibrator**
A programmable voltage/current source that includes a high-performance DMM.
- ◆ **Many sourcing functions**
In addition to constant voltage and current sourcing, voltage pulses can also be sourced, suitable for applications such as flow meter calibration.
- ◆ **Extensive measuring functions**
DMM functions including AC/DC voltage and current, resistance, frequency, temperature measurement, diode and continuity test are fully supported.
- ◆ **Supports various maintenance, adjustment and testing applications**
The multi-function high-precision source supports maintenance of instrumentation systems and plants, calibration of industrial measuring instruments, and electrical circuit testing.
- ◆ **PC control and data acquisition with an optional communications package**
Using the separately available Model 3856-01 COMMUNICATION PACKAGE (RS-232C) or 3856-02 COMMUNICATION PACKAGE(USB) communications package, signal source settings can be made on a PC, and measured values transferred to a PC.

1.2 Features

- ◆ Sources bipolar DC voltage from -15.000 to 15.000 V (@100 μ V finest resolution) and DC current from -25.000 to 25.000 mA (@1 μ A finest resolution), including sink (absorbed current) and source output.
- ◆ Voltage pulses at one of 28 frequencies from 0.5 to 48000 Hz can be generated with settable duty cycle, pulse width and amplitude.
- ◆ For each function and range, source settings can be stored in memory for up to 16 steps, which can then be output in sequence continuously, singly or manually using the Scan sourcing function.
- ◆ Measures true effective value (rms) AC/DC voltage and current (with crest factor less than three).
- ◆ As well as measuring AC/DC voltage and current, the meter also tests continuity and measures resistance, diodes, frequency and temperature (using an IEC584-1:1995-compliant type K thermocouple).

1.3 Names of Parts

Front

Display (LCD)
❖ 1.4 "Display (LCD)" (14.p)

Buttons
❖ (12 p.)

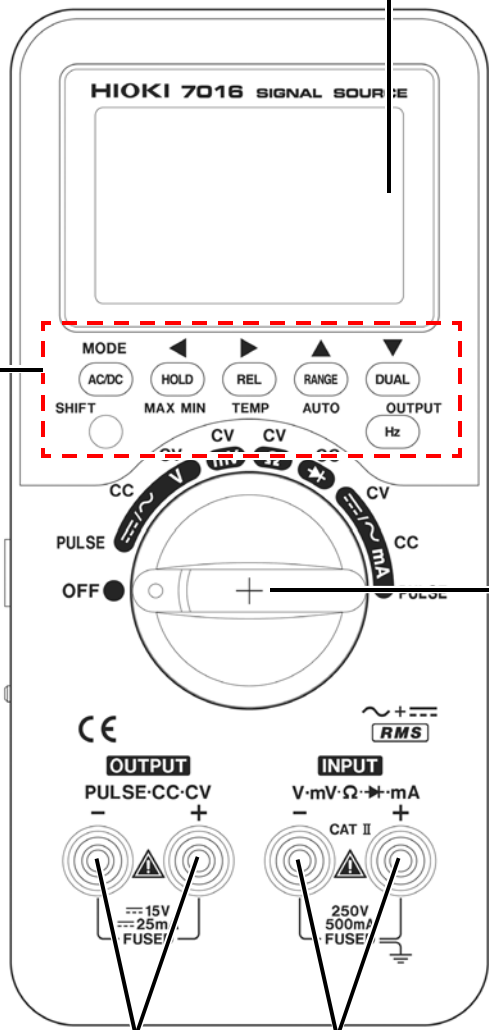

Function selector
❖ 2.5 "Function Selection" (24.p)

Output terminal
❖ 2.3 "Connecting the Test Leads" (21.p)

Input terminal
❖ 2.3 "Connecting the Test Leads" (21.p)

Buttons

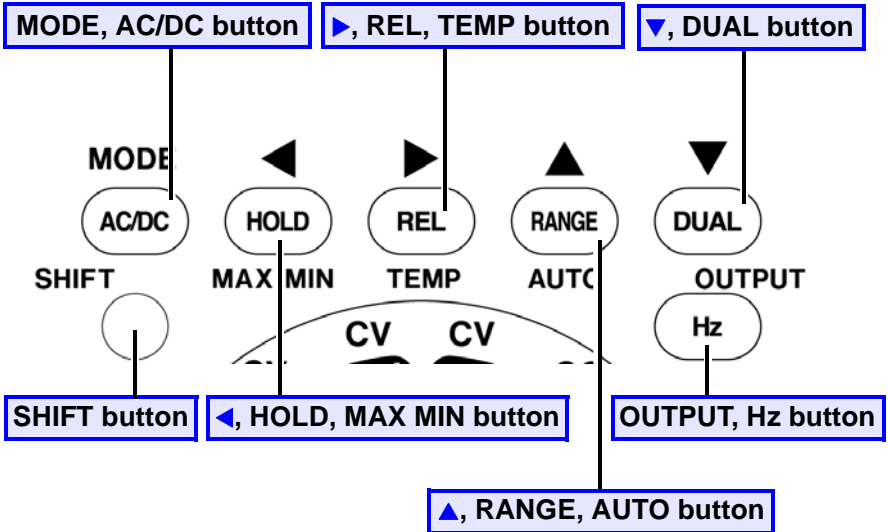

- ❖ Detail→ "Source Mode Button Functions" (27.p),
"Measurement Mode Button Functions" (29.p)

Important!

- Source-function related button operations are indicated by yellow labels on the meter.
- The [SHIFT] button switches between source and measurement functions.

Side

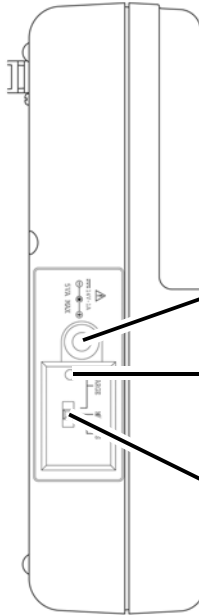
**Jack for AC adapter**

❖ 2.1 "Connecting the AC Adapter" (19.p)

Charging lamp

❖ 2.2 "Charging the Internal Batteries" (20.p)

Slide switch

❖ 2.2 "Charging the Internal Batteries" (20.p)

Back

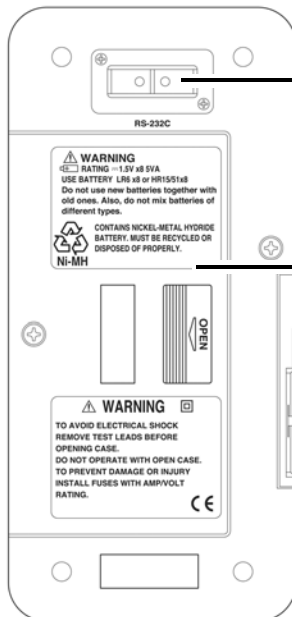
**Connector for RS-232C**

❖ 5.3 "RS-232C Communication Functions" (75.p)

Battery cover

❖ 8.1 "Replacing the Batteries" (96.p)

WARNING
 RATING: 1.5V x8 5/1A
 USE BATTERY LR6 x8 or HR1501x8
 Do not use new batteries together with old ones. Also, do not mix batteries of different types.

CONTAINS NICKEL-METAL HYDRIDE BATTERY. MUST BE RECYCLED OR DISPOSED OF PROPERLY.
 NI-MH

WARNING
 TO AVOID ELECTRICAL SHOCK REMOVE TEST LEADS BEFORE OPENING CASE.
 DO NOT OPERATE WITH OPEN CASE.
 TO PREVENT DAMAGE OR INJURY INSTALL FUSES WITH AMP/VOLT RATING.

CE

1.4 Display (LCD)

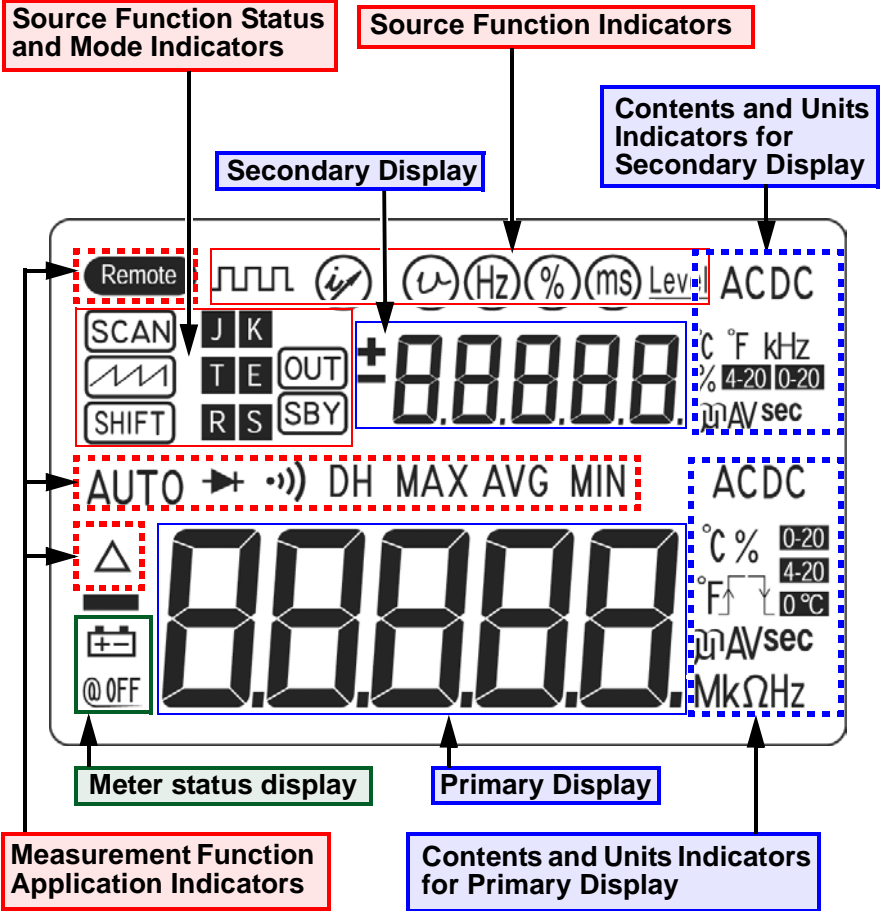



Meter status display

	Indicates low battery voltage (below the guaranteed accuracy voltage - approximately 8 V). It blinks.
@OFF	Indicates the Auto Power Off function is enabled.

Primary Display

-888888	Shows measured value.
---------	-----------------------

Contents and Units Indicators for Primary Display

DC	Indicates measurement of DC voltage (DCV) or current (DCA).
AC	Indicates measurement of AC voltage (ACV) or current (ACA).
ACDC	Indicates measurement of DC + AC voltage (ACDCV) or current (ACDCA).
°C	Unit of temperature measurement
%	Indicates percentage measurement of duty cycle or 0-20 or 4-20 mA.
m sec	Unit of pulse width measurement
	Indicates negative trigger slope when measuring duty cycle or pulse width.
	Indicates positive trigger slope when measuring duty cycle or pulse width.
mA	Unit of current measurement
mV, V	Unit of voltage measurement
Hz, kHz	Unit of frequency measurement
MΩ, kΩ, Ω	Unit of resistance measurement
0°C	Indicates standard connection is normalized to 0°C.
0-20	Indicates displayed value is percentage of 0-20 mA measurement current.
4-20	Indicates displayed value is percentage of 4-20 mA measurement current.

Secondary Display









Shows either measured or sourced value.





Contents and Units Indicators for Secondary Display

DC	Indicates measurement of DC voltage (DCV) or current (DCA).
AC	Indicates measurement of AC voltage (ACV) or current (ACA).
ACDC	Indicates measurement of DC + AC voltage (ACDCV) or current (ACDCA).
°C	Unit of temperature measurement
%	Indicates percentage measurement of duty cycle or setting of pulse duty cycle.
m sec	Unit of pulse width measurement and setting
mA	Unit of current measurement and constant current (CC) sourcing
mV, V	Unit of voltage measurement and constant voltage (CV) sourcing
Hz, kHz	Unit of frequency measurement and pulse frequency setting
0-20	Indicates displayed value is percentage of 0-20 mA measurement current.
4-20	Indicates displayed value is percentage of 4-20 mA measurement current.







Source Function Indicators

	Pulse source function is active.
	Constant current (CC) source function is active.
	Constant voltage (CV) source function is active.
	Pulse source frequency setting
	Pulse source duty cycle setting
	Pulse source pulse width setting
Level	Pulse source amplitude setting

Source Function Status and Mode Indicators

	Indicates no signal is being output.
	Indicates a signal is being output (sourced or generated).
	Indicates the [SHIFT] button is pressed (Source Function settings enabled).
	Indicates ramp generation.
	Indicates scan generation.

Measurement Function Application Indicators

	+	Diode test is active.
		Continuity test is active.
DH		Data Hold and Refresh Hold are enabled.
MAX AVG MIN		Recording function is active.
MAX		Maximum value is displayed.
AVG		Average value is displayed.
MIN		Minimum value is displayed.
DH MAX		Maximum value of 1-ms Peak Hold is displayed.
DH MIN		Minimum value of 1-ms Peak Hold is displayed.
AUTO		Autoranging mode is enabled.
		Relative measurement function is enabled.
		RS-232C communication function is active.
		Indicates the thermocouple is being used.

1.5 Sourcing and Measurement Procedures

1. Preparations

- Connecting the AC Adapter ❖ 2.1 (19 p.)
- Charging the Internal Batteries ❖ 2.2 (20 p.)
- Connecting the test leads ❖ 2.3 (21 p.)

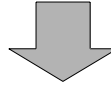

2. Turning Power On

- ❖ 2.4 (23 p.)

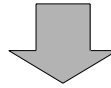

3. Function Settings

- Source Settings ❖ 2.5.1 (24 p.)
- Measurement Settings ❖ 2.5.2 (28 p.)

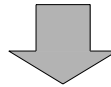

4. Sourcing

- Constant Voltage ❖ 3.1 (32 p.)
- Constant Current ❖ 3.2 (35 p.)
- Pulses ❖ 3.3 (37 p.)
- Memory ❖ 3.4 (39 p.)

Or

5. Measuring

- Voltage ❖ 4.1 (52 p.)
- Current ❖ 4.2 (54 p.)
- Frequency ❖ 4.3 (56 p.)
- Resistance (Continuity) ❖ 4.4 (57 p.)
- Diodes ❖ 4.5 (59 p.)
- Temperature ❖ 4.6 (60 p.)

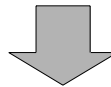

6. Turning Power Off

- ❖ 2.4 (23 p.)

Preparations

2

2.1 Connecting the AC Adapter



! WARNING

- Use only the supplied AC adapter (SA-141A0F-11). AC adapter input voltage range is 100 to 240 VAC (with $\pm 10\%$ stability) at 50/60 Hz. To avoid electrical hazards and damage to the instrument, do not apply voltage outside of this range.
- To avoid the possibility of electric shock, always connect the green wire of the AC adapter to ground.
- Do not use an AC adapter other than the one supplied. Doing so could cause damage to the instrument or other electrical mishap.
- Do not use the supplied AC adapter with another device. It could damage the device or cause another electrical mishap.

Connection Procedures

1. Set the slide switch on the meter as follows:

- [CHARGE]: to charge the batteries
- [M] : to measure only
- [M/S] : to both measure and source signals

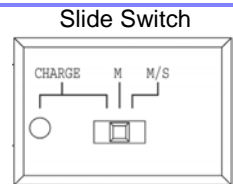

2.

Connect the output plug from the AC adapter to the jack on the side of meter.

Jack for AC adapter

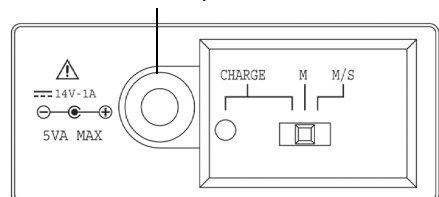

3. Verify that the mains voltage matches the input voltage of the AC adapter, and plug the adapter into an outlet.

2.2 Charging the Internal Batteries



Do not attempt to charge any batteries other than the supplied battery pack (Ni-MH battery). The instrument could overheat and the batteries could explode.

While using the supplied battery pack (8 Ni-MH batteries), use the following procedure to charge the batteries when the battery warning () indicator appears on the LCD.

Charging Procedure

1.

Turn the function selector to **[OFF]**.

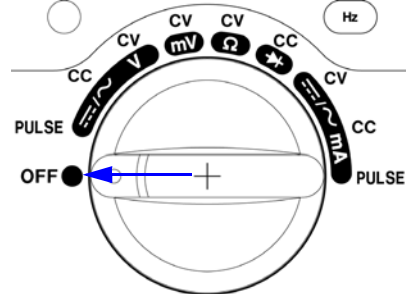

2.

Move the slide switch to **[CHARGE]**.

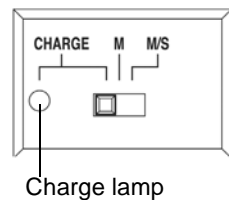

3. Connect the AC adapter to the jack on the side of the meter.
4. The charge lamp lights red as charging begins.
5. The charge lamp turns green when charging is finished.

NOTE

The supplied AC adapter operates from 100 to 250 VAC @47 to 63 Hz). The jack on the side of the meter accepts 14 VDC \pm 10%, center contact positive (+).

2.3 Connecting the Test Leads



The meter has two pair of terminals, labeled Input and Output. The supplied Model 3851-10 TEST LEAD with probes (one each red and black) are for connection to the Input terminals, and the other supplied test leads with clips (one each, red, black and yellow) are for the Output terminals.

For Input Terminals

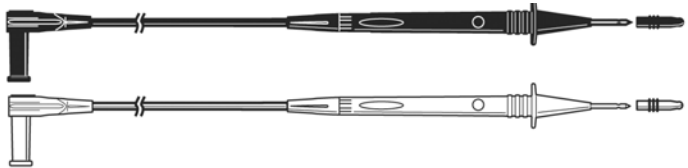

3851-10 TEST LEAD (one each red and black, for Input terminal)

For Output Terminals



Test leads (one each red and black, for Output terminal)



Test lead (Yellow, with 15-V zener diode)

2.3.1 Connections

1.

Connect the the 3851-10 TEST LEAD to the Input terminals.

Connect the red Model 3851-10 TEST LEAD to the "+" INPUT terminal, and the black Model 3851-10 TEST LEAD to the "-" INPUT terminal.

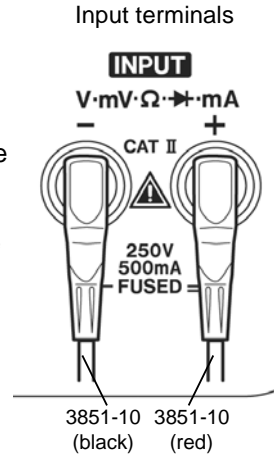

2.

Connect the test leads to the Output terminals

Connect red test lead to the "+" OUTPUT terminal, and the black test lead to the "-" OUTPUT terminal.

Only make connections when the source function is OFF.

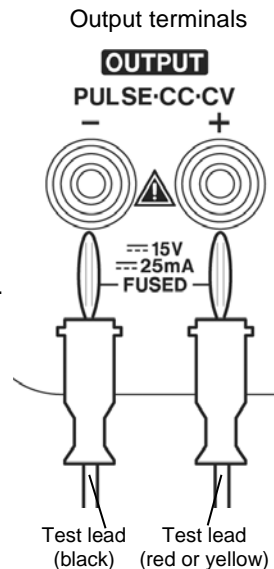

❖ Using the yellow test lead → 6.2 "Loop Test" (81 p.)

2.4 Turning Power On / Off

The meter is turned on and off by both the slide switch and the function selector.

Turning Power On

Measure only

1. Set the slide switch to [M].
2. Set the function selector to the desired measurement function.
 - ❖ 2.5 "Function Selection" (24 p.)

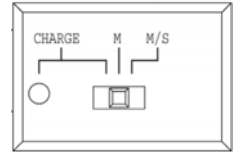

Source only, or

Source and measure simultaneously

1. Set the slide switch to [M/S].
2. Set the function selector to the desired source or measurement function.
 - ❖ 2.5 "Function Selection" (24 p.)

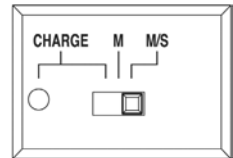

Turning Power Off

Set the function selector to [OFF].

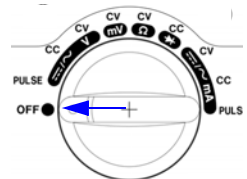

NOTE

- To prevent battery discharge when the meter is not in use, set the function selector to [OFF] or set the slide switch to [M] or [M/S].
- Although measurement-only operation is possible with the slide switch set to [M/S], operating time per battery charge will be shortened.

2.5 Function Selection

Select the desired function.

Important!

- The outer yellow labels around the function selector are for source-related functions.
- The inner reverse-color labels are for measurement-related functions.
- The [SHIFT] button switches between source- and measurement-related button functions.

2.5.1 Source Function Settings

There are three types of source functions:

- Constant-voltage (**CV**) source
- Constant-current (**CC**) source
- Pulse source (**PULSE**)

The source functions are indicated by **yellow labels**. Set the function selector to the function you want to set up.

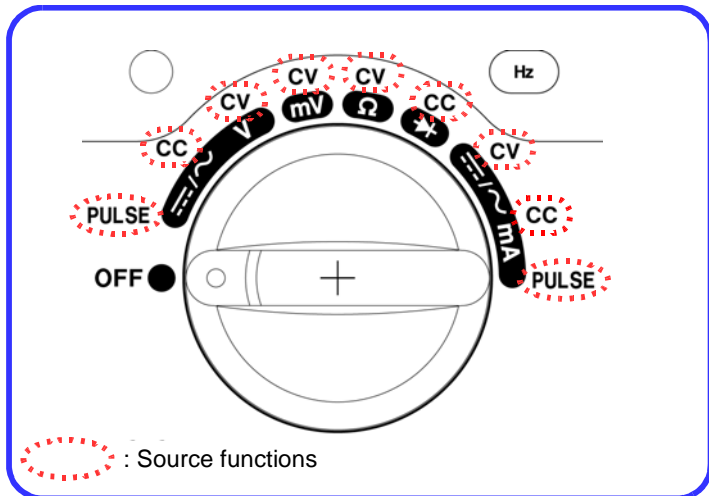

Setting Procedure

1. Press the [SHIFT] button (so the  indicator is displayed).



This enables the source-related button functions.

2. Press the [MODE] button as necessary to select the desired source mode.

The source mode selection order is as follows.

When constant-voltage sourcing (CV) is selected
(The  is indicator is displayed)

Constant-voltage source
1.5 V range



Constant-voltage source
15 V range



Constant-voltage SCAN source
1.5 V range

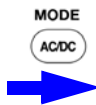
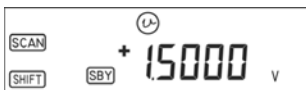

Constant-voltage RAMP source
15 V range

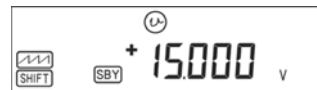

Constant-voltage RAMP source
1.5 V range



Constant-voltage SCAN source
15 V range



SCAN source: The  indicator is displayed.

RAMP source: The  indicator is displayed.

When constant current sourcing (CC) is selected (The indicator is displayed)

Constant current source



MODE

AC/DC

MODE

AC/DC

Constant current SCAN source



MODE

AC/DC

SCAN source: The  indicator is displayed.

RAMP source: The  indicator is displayed.

Constant current RAMP source



When pulse source (PULSE) is selected (The indicator is displayed)

Pulse source frequency



MODE

AC/DC

MODE

AC/DC

Pulse source duty cycle



MODE

AC/DC

Frequency source : The  indicator is displayed.

Duty cycle source : The  indicator is displayed.

Pulse width source: The  indicator is displayed.

Amplitude source : The  indicator is displayed.

Pulse source amplitude



MODE

AC/DC

Pulse source pulse width

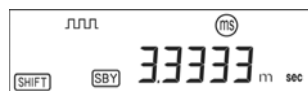

Source Mode Button Functions

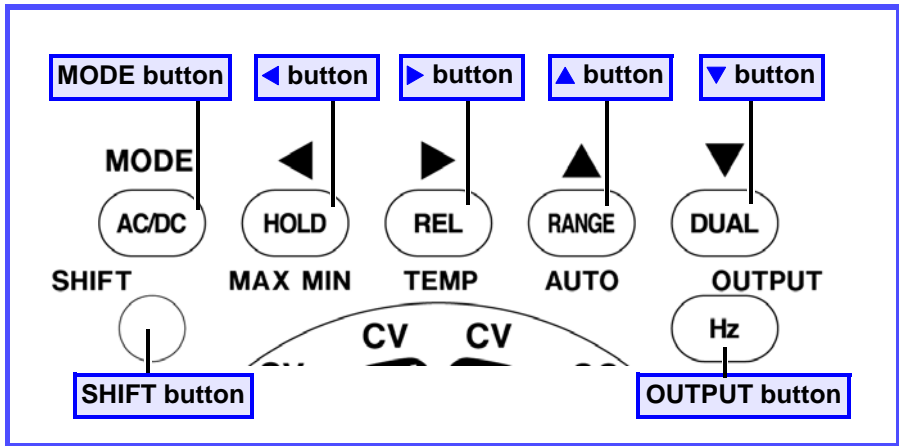

[MODE]

- Switches the source mode when sourcing constant voltage, current or pulses.
- Holding this button for one second activates the memory source setting mode.
- ❖ Detail → 3.4 "Using Memory Function (SCAN and RAMP)" (39 p.)



- Select the digit or polarity(±) to be changed.
- Press these buttons with memory source SCAN or RAMP output to select the source mode.
- ❖ Detail → 3.4.1 "Using the SCAN Function" (40 p.), 3.4.2 "Using the RAMP Function" (45 p.)



- Increments (decrements) the blinking digit by 1.
- Switches output polarity(±).
- When pressed (▲ or ▼) continuously, the value is decreased (increased) automatically.

[SHIFT]

- Press this button to activate the SHIFT mode ([SHIFT] appears).
- While [SHIFT] is displayed, all buttons perform their source-related functions.
- Holding this button for one second toggles the LCD backlight on and off (even when the [SHIFT] button is not pressed, the backlight turns off automatically after a preset time).
- ❖ To set the backlight power-on option → 5.4 "Power-On Options" (76 p.)

[OUTPUT]

- Toggles source output on and off.
- [OUT] is displayed when source output is active, and [SBY] is displayed when source output is inactive.
- Press this button to store settings for later output as SCAN or RAMP memory source output values (proceeding to another step without pressing this button invalidates the settings up to this point).
- ❖ Detailed Descriptions and Operation Procedures → 3.4 "Using Memory Function (SCAN and RAMP)" (39 p.)

2.5.2 Measurement Function Settings

There are five types of measurement functions.

Voltage measurement (V, mV)	❖ 4.1 (52 p.)
Current measurement	❖ 4.2 (54 p.)
Resistance measurement	❖ 4.4 (57 p.)
Diode test	❖ 4.5 (59 p.)
Temperature measurement	❖ 4.6 (60 p.)

Measurement functions are indicated by dark labels (on white background). Set the function selector to the function you want to set up.

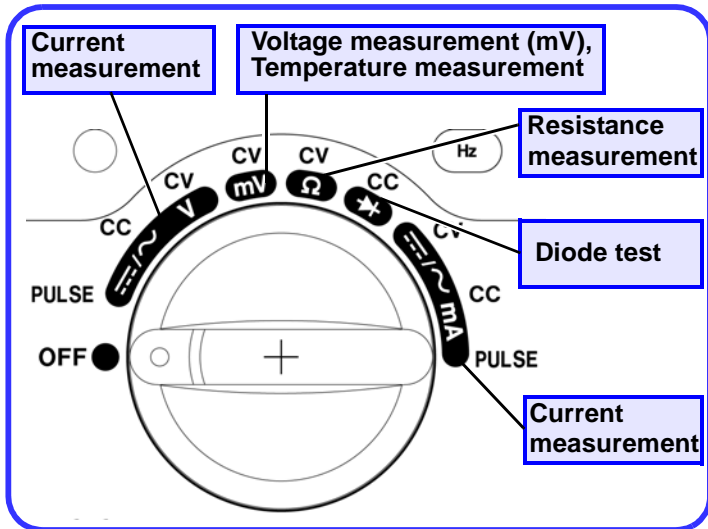

Measurement Mode Button Functions

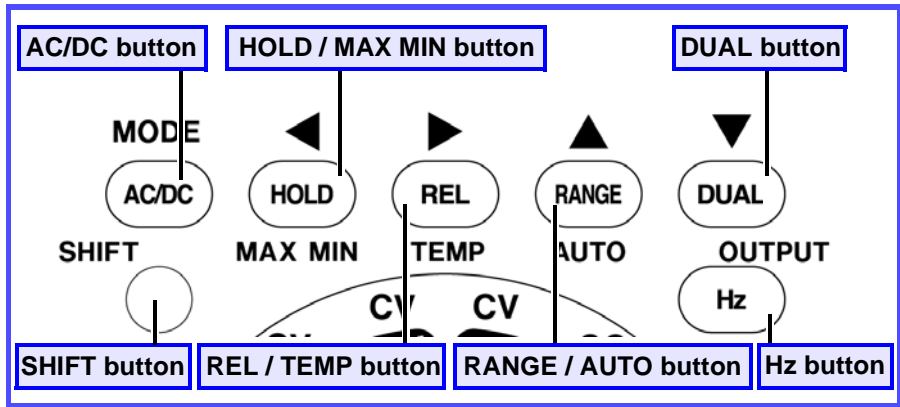

<p>[AC/DC]</p>	<ul style="list-style-type: none"> • Selects DC, AC or ACDC. • When measuring resistance, enables and disables continuity (CONT) testing. • When measuring duty cycle (DUTY) or pulse width (WIDTH), holding this button for one second toggles the trigger slope between rising and falling edges. • Holding this button for one second toggles the 1-ms Peak Hold function on and off.
<p>[HOLD/MAX MIN]</p>	<ul style="list-style-type: none"> • Enables and disables the Data Hold function. • Enables the Refresh Hold function. ❖ 4.8.2 "Data Hold / Refresh Hold Function" (66 p.) • Toggles through MAX, AVG and MIN. ❖ 4.8.1 "Recording Function" (63 p.)
<p>[REL/TEMP]</p>	<ul style="list-style-type: none"> • Enables and disables relative (relative value display) function. ❖ 4.8.3 "Relative (relative display) Function" (67 p.) • When mV measurement is selected, holding this button for one second enables temperature (TEMP) measurement.
<p>[RANGE/ AUTO]</p>	<ul style="list-style-type: none"> • Toggles between auto- and manual ranging. • Changes ranges when manual ranging is enabled.
<p>[DUAL]</p>	<ul style="list-style-type: none"> • Selects various Dual Display* combinations.
<p>[SHIFT]</p>	<ul style="list-style-type: none"> • Toggles the SHIFT mode ([SHIFT] appears when active). • While [SHIFT] is displayed, all buttons perform their source-related functions, <u>so be sure that [SHIFT] is not displayed before performing button operations for measurement functions.</u> • Holding this button for one second toggles the LCD backlight on and off (even when the [SHIFT] button is not pressed, the backlight turns off automatically after a preset time). ❖ 5.4 "Power-On Options" (76 p.)
<p>[Hz]</p>	<ul style="list-style-type: none"> • Changes the measurement mode (frequency, duty cycle or pulse width) when using the Dual Display function. ❖ 4.8.5 "Dual Display Function" (70 p.)

Using Source Functions



3

CAUTION

Please observe the following precautions to avoid damage to the instrument:

- Do not connect a device to be measured while the instrument is turned off.
- Do not turn the instrument off and on or move the function switch while a test device is connected for measurement.
- Always make sure to turn the source output off before changing the connections at the OUTPUT terminals or device under test.
- Never connect the instrument to another voltage source when using it to source voltage, or to another current source when using it to source current. The instrument or device under test could be damaged.
- Use the supplied yellow test lead when performing loop testing of internally powered instruments.

NOTE

- To use this instrument's source function, set the slide switch to the [M/S] position. Source output is disabled in the other switch positions.
- Holding the [▲/▼] buttons changes the setting continuously within the settable range.
- In source (output) mode, the occurrence of electrostatic discharge at the output terminals can cause output to be interrupted and the standby mode enabled ([SBY] appears).
- In source (output) mode, if battery voltage falls below the level necessary to maintain stable output, output is interrupted and the standby mode is enabled ([SBY] appears).

Important!

- The yellow labels around the outer circumference of the function selector indicate signal source/generation functions.
- The [SHIFT] button must first be pressed to enable the source-related button functions. ([SHIFT] is displayed on the LCD.)

- ❖ 2.5.1 "Source Function Settings" (24 p.), "Source Mode Button Functions" (27 p.)

3.1 Constant-Voltage Source (DCCV)

This mode outputs a constant voltage at the set value regardless of load.

Procedure

1.

Set the slide switch to the **[M/S]** position.

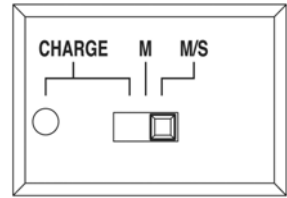

2.

Set the function selector to the **[CV]** position.

Select one position.
When source only, any **[CV]** position can be selected.

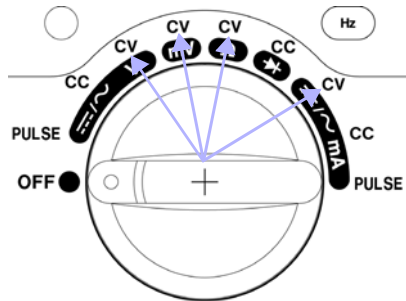

3. Press the **[SHIFT]** button and confirm that **[SHIFT]** is displayed on the LCD.



The source-related button functions are now enabled.

4. Press the [MODE] button as necessary to select the source mode on the secondary display.



Pressing the [MODE] button repeatedly changes the source mode as shown below.

Selecting the Source Mode (The indicator is displayed)

Constant-voltage source
1.5 V range



Constant-voltage source
15 V range



Constant-voltage SCAN source
1.5 V range

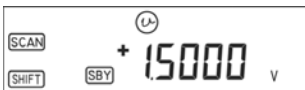

SCAN source: The  indicator is displayed.

RAMP source: The  indicator is displayed.

Constant-voltage RAMP source
15 V range



Constant-voltage RAMP source
1.5 V range



Constant-voltage SCAN source
15 V range

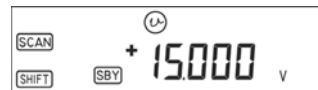

5. Press the [◀] or [▶] button to select a digit to change.
6. Press the [▲] or [▼] button to set a value.

Settable Ranges

[+0.0000 V]	-1.5000 V to 1.5000 V
[+00.000 V]	-15.000 V to 15.000 V

7. Press the [OUTPUT] button to output the set voltage value. Verify that [OUT] is displayed on the LCD.

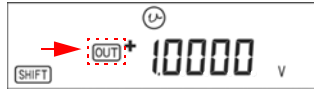

8. Press the [OUTPUT] button again to disable output. Verify that [OUT] is no longer displayed.

NOTE

- To change the setting value, repeat Steps 5 and 6.
- If an overload such as a short circuit occurs while sourcing voltage, output is disabled and the standby state is enabled ([SBY] lit), or the meter may be turned off by the internal protection circuitry. If the power is turned off, wait a short time before turning it back on.

3.2 Constant-Current Source (DCCC)

This mode outputs a constant current at the set value regardless of load.

Procedure

1. Set the slide switch to the [M/S] position.

2.

Set the function selector to the [CC] position.

Select one position.
When source only, any [CC] position can be selected.

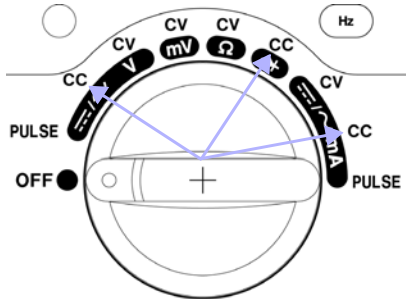

3. Press the [SHIFT] button and confirm that [SHIFT] is displayed on the LCD.
4. Press the [MODE] button as necessary to select the source mode on the secondary display.



Pressing the [MODE] button repeatedly changes the source mode as shown (page 36).

Selecting the Source Mode

(The  indicator is displayed)

Constant current source



MODE

AC/DC

Constant current RAMP source



MODE

AC/DC

Constant current SCAN source



MODE

AC/DC

SCAN source: The  indicator is displayed.

RAMP source: The  indicator is displayed.

5. Press the [] or [] button to select a digit to change.

6. Press the [] or [] button to set a value.

Settable range

[+00.000 mA] -25.000 mA to 25.000 mA

7. Press the **[OUTPUT]** button to output the set current value. Verify that  is displayed on the LCD.

8. Press the **[OUTPUT]** button again to disable output. Verify that  is no longer displayed.

NOTE

- To change the setting value, repeat Steps 5 and 6.
- In current source (output) mode, if overloading occurs (such as from an open-circuit load), output voltage is maintained at the instrument's maximum limit.

3.3 Pulse Source (PULSE)

- In addition to flow meter calibration, the pulse source can be used for checking and calibrating counters, rotation counters, oscilloscopes, frequency converters and other frequency-input systems.
- Frequency, duty cycle, pulse width and amplitude can be set.

Procedure

1. Set the slide switch to the [M/S] position.

2.

Set the function selector to the [PULSE] position.

Select one position.
When source only, any [PULSE] position can be selected.

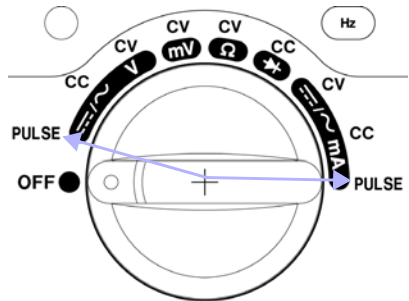

3. Press the [SHIFT] button and confirm that [SHIFT] is displayed on the LCD.
4. Press the [MODE] button to select a parameter for setting.



Pressing the [MODE] button repeatedly changes the parameter as shown (page 38).

Selecting the Parameter

(The  is indicator is displayed)

Pulse source frequency

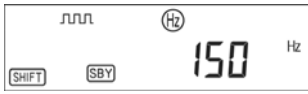

MODE

AC/DC



Pulse source amplitude

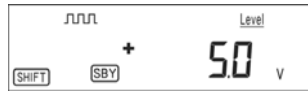

MODE

AC/DC



Pulse source duty cycle







MODE

AC/DC

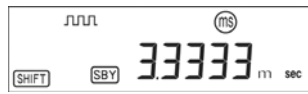



Pulse source pulse width





Frequency source: The  indicator is displayed., Duty cycle source: The  indicator is displayed.
 Pulse width source: The  indicator is displayed., Amplitude source: The  indicator is displayed.

The values displayed above are the default settings.

5. Press the [] or [] button to set a value.

Settable Ranges

Frequency	0.5, 1, 2, 5, 10, 15, 20, 25, 30, 40, 50, 60, 75, 80, 100, 120, 150, 200, 240, 300, 400, 480, 600, 800, 1200, 1600, 2400, 4800 (Hz)
Duty cycle	As there are 256 settable steps, each step is 0.390625%, which is displayed as 0.39% per step increments. Example: If an initial value of 50.00% is incremented by one step, the display shows 50.39%.
Pulse width	As there are 256 settable steps, the pulse width per step is $1/(256 * \text{frequency})$.
Amplitude	+5V, ± 5 V, +12 V, ± 12 V

6. Press the [**OUTPUT**] button to output the set pulse value. Verify that  is displayed on the LCD.
7. Press the [**OUTPUT**] button again to disable output. Verify that  is no longer displayed.

NOTE

If an overload such as a short circuit occurs while sourcing voltage, output is disabled and the standby state is enabled ( lit), or the meter may be turned off by the internal protection circuitry. If the power is turned off, wait a short time before turning it back on.

3.4 Using Memory Function (SCAN and RAMP)

These two functions are convenient for constant-voltage and constant-current sourcing.

S C A N Function	Up to 16 steps of different source values and time intervals can be set.	❖ 3.4.1 (40 p.)
R A M P Function	A dual slope* can be generated to simulate a linear waveform. The number of divisions in each slope can be set.	❖ 3.4.2 (45 p.)

* Dual slope: two slopes.

The number of divisions between the start and end levels, and from the end level to the next start level can be set for each slope.

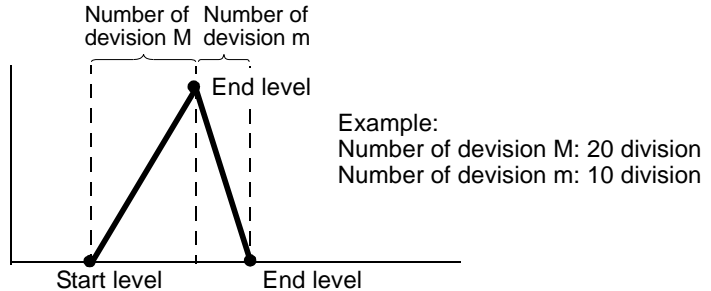

These functions are described next.

3.4.1 Using the SCAN Function

Procedure

1. Set the slide switch to the [M/S] position.
2. Set the function selector to the [CV] position to source voltage, or to the [CC] position to source current.
3. Press the [SHIFT] button and confirm that **SHIFT** is displayed on the LCD.
4. Press the [MODE] button as necessary to select the source mode on the secondary display



Pressing the [MODE] button repeatedly changes the source mode as shown below.
During SCAN function setup, **SCAN** is displayed.

Selecting the Source Mode

Voltage source SCAN±1.5 V	Current source SCAN±25 mA
MODE 	
SCAN±15 V	

SCAN function factory default settings

Range	SCAN±1.5000 V	SCAN±15.000 V	SCAN±25.000 mA	Time Interval
Step	Output Value	Output Value	Output Value	
1	+1.5000 V	+15.000 V	+00.000 mA	2 S
2	+1.2000 V	+12.000 V	+04.000 mA	2 S
3	+0.9000 V	+09.000 V	+08.000 mA	2 S
4	+0.6000 V	+06.000 V	+12.000 mA	2 S
5	+0.3000 V	+03.000 V	+16.000 mA	2 S
6	+0.0000 V	+00.000 V	+20.000 mA	2 S
7	-0.3000 V	-03.000 V	+16.000 mA	2 S
8	-0.6000 V	-06.000 V	+12.000 mA	2 S
9	-0.9000 V	-09.000 V	+08.000 mA	2 S
10	-1.2000 V	-12.000 V	+04.000 mA	2 S
11	-1.5000 V	-15.000 V	+00.000 mA	2 S
12	+0.0000 V	+00.000 V	+04.000 mA	0 S
13	+0.0000 V	+00.000 V	+08.000 mA	0 S
14	+0.0000 V	+00.000 V	+12.000 mA	0 S
15	-1.5000 V	-15.000 V	+16.000 mA	0 S
16	+0.0000 V	+00.000 V	+20.000 mA	0 S



Do you want to change the values from the factory default settings?

❖ "Changing Data Settings" (44 p.)

5. When finished making SCAN function settings, press the [◀] or [▶] button to select the SCAN source mode.



Pressing the [◀] or [▶] button changes the secondary display as follows.

Selecting the SCAN Source Mode

Continuouse (Cont)



Cycle (CyCLE)

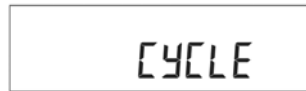

Step (StEP)

Cont	<ul style="list-style-type: none"> • Output proceeds sequentially from the first step to the last, then returns to the first step and repeats continuously. • However, if the time interval of the last step is set to 0 seconds, it is ignored, and output continues from the first step. <p>Example: When the factory default settings for Step 12 is 0 seconds, after output from Step 11, output continues from Step 1.</p>
CyCLE	<ul style="list-style-type: none"> • Output proceeds sequentially from the first step to the last, then continues output at the settings of the last step. • However, if the time interval of a step is set to 0 seconds, output continues according to the settings of the previous step. <p>Example: When the factory default settings for Step 12 is 0 seconds, output from Step 11 is maintained continuously.</p>
StEP	Pressing the [▲] or [▼] button moves to the previous or next output step. The value set for each step is output until the next step is selected.

3.4 Using Memory Function (SCAN and RAMP)

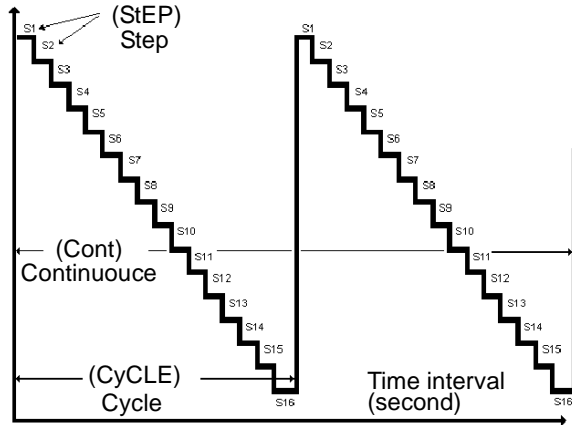

6. Press the [OUTPUT] button to output the set voltage value. Verify that OUT is displayed on the LCD.

7. Press the [OUTPUT] button again to disable output. Verify that OUT is no longer displayed.

- Continuous (**CONT**) and Cycle (**CyCLE**) source modes always start at Step 1.
- If the time interval of Step 1 is set to 0s, the source out put is not activated. (Except for STEP source mode)
- When Continuous (**CONT**) and Cycle (**CyCLE**) source modes are stopped by the [OUTPUT] button, subsequent source output resumes at Step 1.

Changing Data Settings

1. With the SCAN function active, hold the [MODE] button for one second to enter the data setting mode for each source step.
2. Set the time interval and source output value for each step. The secondary display shows the output value, the leftmost two digits of the primary display show the step number, and the rightmost two digits show the time interval.

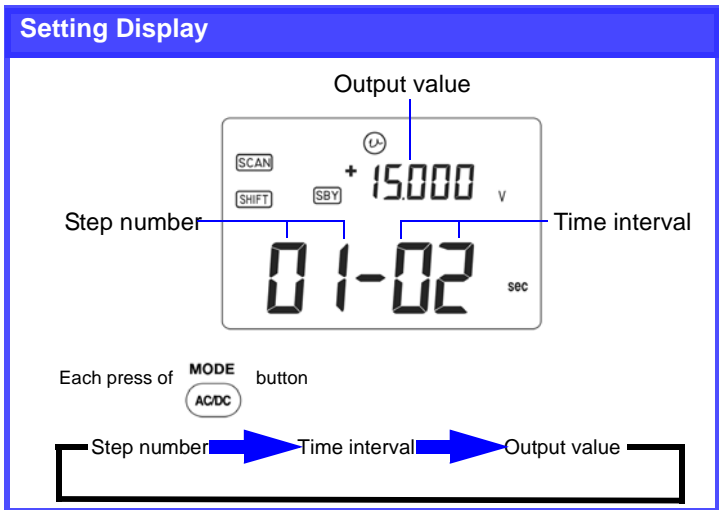

3. Press the [MODE] button to select the step number, time interval or output value. The parameter digit to be set blinks.



- Press the [▲] or [▼] button to increment or decrement the value, and press the [◀] or [▶] button to move to another digit of the output value.
- Time intervals can be set from 0 to 99 seconds.

4. Press the [OUTPUT] button to save your settings.
5. To clear all settings, hold the [▶] button for one second. Time interval and output values are cleared to zero.
6. Hold the [MODE] button for one second to exit the step data setting mode.

3.4.2 Using the RAMP Function





Procedure

1. Set the slide switch to the [MS] position.
2. Set the function selector to the [CV] position to source voltage, or to the [CC] position to source current.
3. Press the [SHIFT] button and confirm that [SHIFT] is displayed on the LCD.
4. Press the [MODE] button as necessary to select the source mode on the secondary display.



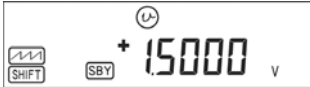

Pressing the [MODE] button repeatedly changes the source mode as shown below.
During RAMP function setup,  is displayed.

Selecting the Source Mode

Voltage source RAMP±1.5 V	Current source RAMP±25 mA
	
 <div style="display: inline-block; text-align: center;"> <p>MODE</p> <p> RAMP±15 V</p> </div>	
	

RAMP function factory default settings

	 ±1.5000 V		 ±15.000 V		 ±25.000 mA	
	Output value	Number of division	Output value	Number of division	Output value	Number of division
Start	-1.5000 V	015	-15.000 V	015	-25.000 mA	025
End	+1.5000 V	015	+15.000 V	015	+25.000 mA	025



Do you want to change the values from the factory default settings?

❖ "Changing Data Settings" (47 p.)

5. When finished making source mode settings, press the [◀] or [▶] button to select the RAMP source mode.



Pressing the [◀] or [▶] button changes the secondary display as follows.

Selecting the RAMP Source Mode

Continuouse (Cont)

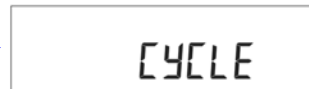
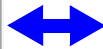

Cycle (CyCLE)

**Cont**

- After the first slope is output (start to end values), the second slope is output to return to the start value, forming one repeatable cycle.
- The interval of the first slope = (end output value - start output value) / divisions.
Example: The factory default settings with  ±1.5000 V range is $(1.5 + 1.5) / 15 \text{ steps} = 0.2 \text{ V}$.
- The interval of the second slope = (starting output value - end output value) / divisions.

CyCLE

After the first slope is output (start to end values), the starting value of the second slope is output, continuing output according to the settings.

- Press the [OUTPUT] button to output the set voltage value. Verify that [OUT] is displayed on the LCD.



The output value changes according to settings every 0.33 seconds.

- Press the [OUTPUT] button again to disable output. Verify that [OUT] is no longer displayed.

Changing Data Settings

- With the RAMP function active, hold the [MODE] button for one second to enter the data setting mode for each source step.
- The RAMP function involves dual slope generation*. Set the number of divisions from the start to the end position, and from the end to the start position.

Also set the output values of the start and end positions.

* Dual slope generation: generating two slopes.

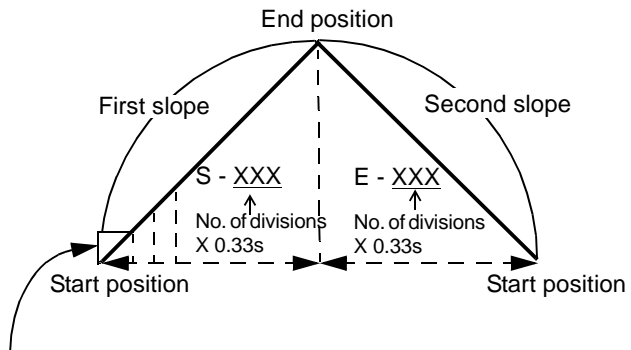

The output value at each interval =
 $(\text{end output value} - \text{start output value}) / \text{divisions}$

3.4 Using Memory Function (SCAN and RAMP)

3. Set the division number and output value for both the start and end positions.

Secondary display	Output value
Leftmost digit of primary display	Start [S] or End [E] position
Rightmost three digits of primary display	Number of divisions

Setting Display

Output value at start position

Output value at end position

When the start position [S] or end position [E] is blinking, press the [▲] or [▼] button.

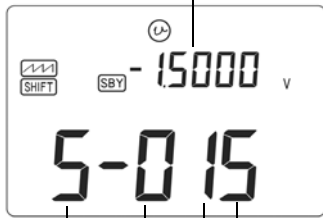

Start position Number of division
(1 to 999)

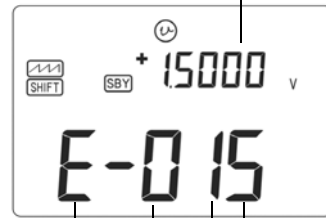

End position Number of division
(1 to 999)

Each press of MODE button



Start position [S] → Number of division → Output value at start position

Each press of [▲], [▼] button

End position [E] → Number of division → Output value at end position

Each press of MODE button



4. Press the [**▲**] or [**▼**] button to select the start position [**S**] or end position [**E**]. Then press the [**MODE**] button to switch between the number of divisions and output value. The parameter digit to be set blinks.



- Press the [**▲**] or [**▼**] button to increment or decrement the value, and press the [**◀**] or [**▶**] button to move to another digit to set.
- The number of divisions can be set from 1 to 999.

5. Press the [**OUTPUT**] button to save your settings.
6. Hold the [**MODE**] button for one second to exit the step data setting mode.

Using Measurement Functions



4

DANGER

Observe the following precautions to avoid electric shock.

- Before connecting the test leads, check the position of the function selector.
- Also, remove the test leads from the device under test before switching the function selector.
- Do not attempt to measure a television's horizontal output signal.

WARNING

The terminal section does not provide safe insulating distance. So to avoid electric shock, disconnect mains power before connecting test leads to the terminals.

NOTE

- Set the slide switch to [M] for measuring only, or to [M/S] if you want to measure and use source functions at the same time
- If the source functions are not used but the slide switch is set to [M/S], continuous operating time per battery charge will be shortened.

4.1 Measuring Voltage



The maximum input voltage is 250 VDC, 250 Vrms (with maximum 10^6 V•Hz voltage-frequency product). Attempting to measure voltage in excess of the maximum input could destroy the instrument and result in personal injury or death.

Procedure

1. Set the slide switch to the **[M]** position.
2. Set the function selector to the **[$\text{---}/\sim\text{V}$]** or **[mV]** position.



- Setting **[mV]** is for 50 mV and 500 mV range measurement.
- Setting **[$\text{---}/\sim\text{V}$]** is for the range over 500 mV measurement.

3. Connect the red 3851-10 TEST LEAD to the (+) INPUT terminal, and the black 3851-10 TEST LEAD to the (-) INPUT terminal.
4. Press the **[AC/DC]** button as needed to select the appropriate voltage measurement function.
5. To enable manual range selection, press the **[RANGE/AUTO]** button (so the **AUTO** indicator is not displayed on the LCD).



- To re-enable auto-ranging, hold the **[RANGE/AUTO]** button for one second.

6. Connect the test leads to the circuit to be measured, and read the displayed value.

- Press the [DUAL] button to activate the Dual Display mode.
- Press the [Hz] button to activate frequency measurement (or duty cycle or pulse width) in the Dual Display mode.
- ❖ Detail→ 4.8.5 "Dual Display Function" (70 p.)

Display Example

Measuring DC voltage



Measuring AC voltage



After pressing the [DUAL] and [AC/DC] buttons



After pressing the [Hz] button



4.2 Measuring Current



Never apply voltage to the test leads when a current measurement function is selected. Doing so may damage the instrument and result in personal injury. To avoid electrical accidents, remove power from the circuit before connecting the test leads.



To avoid electrical shock, do not use the instrument to measure current in circuits of 250 V or greater. The current function overload protection trips at 250 VDC, or 250 Vrms.

Procedure

1. Set the slide switch to the **[M]** position.
2. Set the function selector to the **[$\overline{\text{---}}$ / \sim mA]** position.
3. Connect the red 3851-10 TEST LEAD to the (+) INPUT terminal, and the black 3851-10 TEST LEAD to the (-) INPUT terminal.
4. Press the **[AC/DC]** button as needed to select the appropriate current measurement function.
5. To enable manual range selection, press the **[RANGE/AUTO]** button (so the **AUTO** indicator is not displayed on the LCD).



To re-enable auto-ranging, hold the **[RANGE/AUTO]** button for one second.

6. Connect the test leads to the circuit to be measured, and read the displayed value.

- Press the [DUAL] button to activate the Dual Display mode.
- Press the [Hz] button to activate frequency measurement (or duty cycle or pulse width) in the Dual Display mode.
- ❖ Detail→ 4.8.5 "Dual Display Function" (70 p.)

- "4-20 mA%" displays 4 mA input as 0% and 20 mA input as 100%.
- "0-20 mA%" displays 0 mA input as 0% and 20 mA input as 100%.
- You can select between "4-20 mA%" and "0-20 mA%" display modes in the 5.4 "Power-On Options" (76 p.).

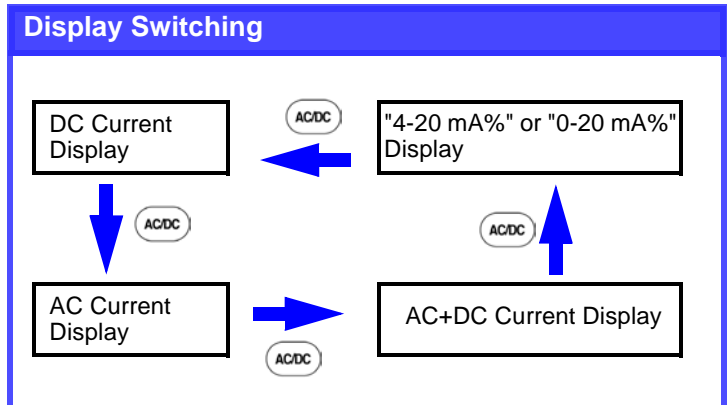

4.3 Measuring Frequency

Procedure

1. Display voltage or current by the procedures in 4.1 (52 p.) or 4.2 (54 p.).
2. Press the [Hz] button and read the displayed voltage.
3. Pressing the [Hz] button repeatedly toggles through Hz, duty cycle and pulse measurement.

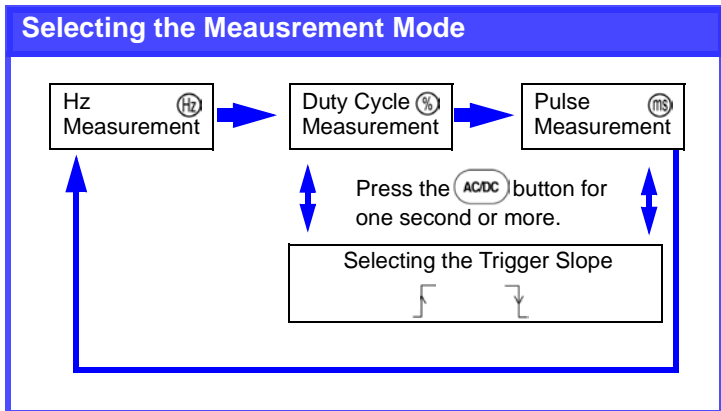

4. Hold the [Hz] button for one second to return to the status in Step 1.

4.4 Measuring Resistance



Never apply voltage to the input terminals when the Resistance function is selected. Doing so may damage the instrument and result in personal injury. To avoid electrical accidents, remove power from the circuit before measuring.

Procedure

1. Set the slide switch to the [M] position.
2. Set the function selector to the [Ω] position
3. Connect the red 3851-10 TEST LEAD to the (+) INPUT terminal, and the black 3851-10 TEST LEAD to the (-) INPUT terminal.
4. Connect the test leads to the circuit to be measured, and read the displayed value.
5. To enable manual range selection, press the [RANGE/AUTO] button (so the AUTO indicator is not displayed on the LCD)



To re-enable auto-ranging, hold the [RANGE/AUTO] button for one second.

6. Pressing the [AC/DC] button toggles the continuity test function on and off (↔) mark is displayed/not displayed). At this time, auto-ranging is disabled.

NOTE

With the resistance measurement function active, short the probe tips together and press the [REL] button to zero out the internal resistance of the probes.

Resistance Measurement Display Example**4.4.1 Continuity Test****Procedure**

1. When the resistance measurement function is active, pressing the [AC/DC] button enables the continuity test function using resistance measurement.



At this point, the 500 Ω range is selected, and if auto-ranging was active, it is disabled and manual ranging is enabled.

- Pressing the [RANGE] button selects each range.
- The beeper sounds whenever the resistance is 1000 counts or less in the selected range.

2. Press the [AC/DC] button again to exit the continuity testing function.

NOTE

- While the continuity test function is active, holding the [RANGE/AUTO] button for one second activates auto-ranging. In this case, the beeper sounds whenever the measured resistance value is about 10 Ω or less.
- When you cancel the continuity test function, the resistance measurement range does not revert to the range that was active at the time the function was enabled.

Continuity Test Display Example

4.5 Diode Test



Never apply voltage to the input terminals when the Diode Test function is selected. Doing so may damage the instrument and result in personal injury. To avoid electrical accidents, remove power from the circuit before measuring.

Procedure

1. Set the slide switch to the [M] position.
2. Set the function selector to the [▶+] position.
3. Connect the red 3851-10 TEST LEAD to the (+) INPUT terminal, and the black 3851-10 TEST LEAD to the (-) INPUT terminal.
4. Connect the test leads to the circuit to be measured, and read the displayed value.
5. The display appears as follows:

Forward direction	0.3 to 0.8 V forward voltage drop displayed
Reverse direction	[OL] displayed
Short-circuit	Approx. 0 V displayed, and beeper sounds
Open-circuit	[OL] displayed in forward direction

Diode Test Display Example



NOTE

The diode function also works for continuity testing. The beeper sounds at voltage levels of about 50 mV or less.

4.6 Measuring Temperature

Temperature can be measured using an optional temperature probe.

CAUTION

- To avoid damage to the instrument, do not apply voltage or current to temperature probe.
- Do not bend the thermocouple leads, sharply. Repeatedly bending the leads can break them.

Measurement Procedure

1. Set the slide switch to the [M] position.
2. Set the function selector to the [mV] position.
3. Connect the temperature probe to the (+) and (-) INPUT terminals.
4. Hold the [TEMP] button for one second to start temperature measurement.

Temperature Measurement Display Example



NOTE

Pressing the [AC/DC] button displays [0°C] on the LCD. At this point, the reference junction temperature is 0°C.

4.7 Source and Measure Simultaneously

Procedure

1. Set the slide switch to the [M/S] position.

2. Set the function selector.

- **Voltage source:**
Set to [CV] and a measurement function position (dark labels on white background) that will be measured.
- **Current source:**
Set to [CC] and a measurement function position (dark labels on white background) that will be measured.

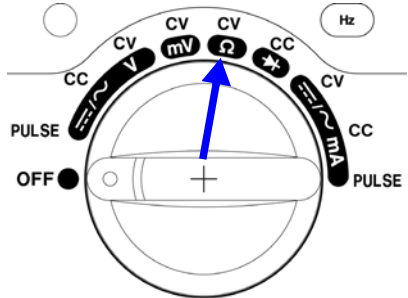

ex. Voltage source and Measuring resistance

Measuring voltage	[$\text{---}/\sim/V$], or [mV]
Measuring current	[$\text{---}/\sim/mA$]
Measuring resistance	[Ω]
Diode Test	[$\rightarrow $]
Measuring temperature	[mV]
Measuring frequency	[$\text{---}/\sim/V$], [mV], or [$\text{---}/\sim/mA$]

- ❖ Follow the appropriate separate procedure from here.
 - Section 3 "Using Source Functions" (31 p.)
 - 4.1 "Measuring Voltage" (52 p.) to 4.6 "Measuring Temperature" (60 p.)

4.8 Special Measurement Functions

This instrument provides the following special measurement functions:

Function	Use	Reference
Recording	For acquiring long-term data and checking for transients.	❖ 4.8.1 (63 p.)
Data Hold and Refresh Hold	Use to simplify reading fluctuating measurements.	❖ 4.8.2 (66 p.)
Relative (relative display)	<ul style="list-style-type: none"> • When you want to zero out the internal resistance of probes • When you want to read only the difference (offset) of a measured value from another value • When you want high-accuracy measurement in the 50 mV DC or DCA ranges 	❖ 4.8.3 (67 p.)
1-ms Peak Hold	Use to determine the crest factor of a waveform, where $crest\ factor = waveform\ peak\ value / true\ rms\ value$	❖ 4.8.4 (68 p.)
Dual Display	Use to monitors two different measurement parameters (voltage, current, frequency, duty cycle or pulse width) of one signal simultaneously.	❖ 4.8.5 (70 p.)

4.8.1 Recording Function

During measurement, maximum (MAX), minimum (MIN) and average (AVG) values can be automatically recorded in memory.



In what situations is it used?

For acquiring long-term data and checking for transients.

Procedure

1. While measuring, hold the [HOLD/MAX MIN] button for one second. MAX AVG MIN appears on the display as the recording function starts.



2. Press the [HOLD/MAX MIN] button to change the display as follows:

Display Indication	Real-time measurement value
MAX AVG MIN	Current measurement value
MAX	Maximum value
MIN	Minimum value
AVG	Average value

3. Hold the [HOLD/MAX MIN] button again for one second to stop the recording function. The MAX AVG MIN indicators disappear from the display.

- The beeper sounds and the relevant value is refreshed when a new maximum or minimum value is recorded.
- When an overload value is measured, calculation of the average value stops, and [OL] is displayed for the average value.



- When the recording function is started with auto-ranging enabled, the maximum (MAX), minimum (MIN) and average (AVG) values can be in different ranges.

**NOTE**

When the recording function is active, the power saver function is disabled, and @OFF does not appear on the display. The average value is the average of all recorded measurements since recording was started.

Recording Display Example

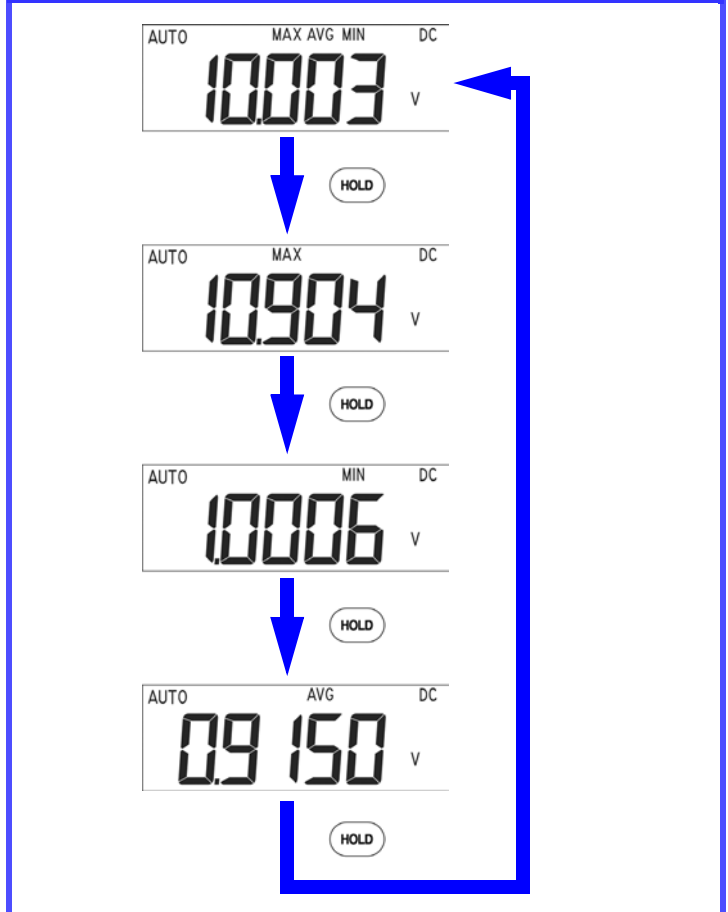

4.8.2 Data Hold / Refresh Hold Function



In what situations is it used?

Use to simplify reading fluctuating measurements.

Data Hold Function

This function holds measured values on the display.

Procedure

1. Press the [HOLD/MAX MIN] button to activate the Data Hold function. DH appears on the display, and the displayed value is held (retained).



2. Press the [HOLD/MAX MIN] button again to measure one time and hold the measurement data.
3. Hold the [HOLD/MAX MIN] button for one second to cancel the Data Hold function. DH disappears from the display.

Refresh Hold Function

- This function automatically refreshes the (held) displayed value when the measured value changes while Data Hold is active.
- The Data Hold function can be changed to the Refresh Hold function in the Power-On Options.
- ❖ 5.4 "Power-On Options" (76 p.)
- If a change occurs that is greater than the count value (100 to 1000) set in the Power-On Options, the value is refreshed (while DH is blinking).

Procedure

1. Press the [HOLD/MAX MIN] button to activate the Refresh Hold function. DH appears on the display.
2. Press the [HOLD/MAX MIN] button for one second to cancel the Refresh Hold function. DH disappears from the display.

4.8.3 Relative (relative display) Function

The function applies to all measurement functions, subtracting a reference value from the measured value and displaying the calculated result.



In what situations is it used?

- When you want to zero out the internal resistance of probes
- When you want to read only the difference (offset) of a measured value from another value
- When you want high-accuracy measurement in the 50 mV DC or DCA ranges

Procedure

1. Press the [REL] button to activate the Relative function.
△ appears on the display.



At this point,

- The displayed value becomes the reference for subsequent measurements, and is redisplayed as zero.
- If measured data is at overload level, [OL] appears on the display.

2. Press the [REL] button again to cancel the Relative function.
△ disappears from the display.

NOTE

- The Relative function cannot be activated if an overload is present ([OL] displayed).
- With the resistance measurement function active, short the probe tips together and press the [REL] button to zero out the internal resistance of the probes.

Zeroing Out Probe Resistance



4.8.4 1-ms Peak Hold Function

- Works with voltage and current measurement functions
- Shows the peak value of an input signal waveform



In what situations is it used?

Use to determine the crest factor of a waveform, where
crest factor = waveform peak value / true rms value

Procedure

1. Hold the [AC/DC] button for one second to activate the 1-ms Peak Hold function. DH MAX appears on the display.



At this point,

- The measurement displayed when the function was activated is held (retained).
- If auto-ranging was enabled, manual ranging is activated with the currently operative range retained.

- Pressing the [HOLD/MAX MIN] button updates the displayed (held) MAX and MIN values.

Display indication	Measurement value
DH MAX	Maximum value
DH MIN	Minimum value

- The beeper sounds when a new maximum or minimum value is measured.
- Pressing the [DUAL] button resets the MAX and MIN values and restarts 1-ms Peak Hold operation. The maximum (MAX) and minimum (MIN) display mode are not changed.

2. Press the [AC/DC] button for one second to cancel the 1-ms Peak Hold function. DH MAX disappears from the display.



Display State Switching

1-ms Peak Hold Function

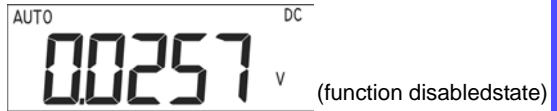

Hold **AC/DC** for one second

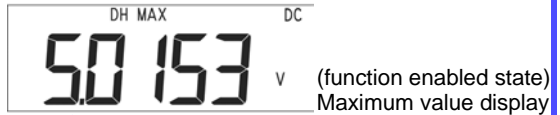

HOLD
MAX MIN

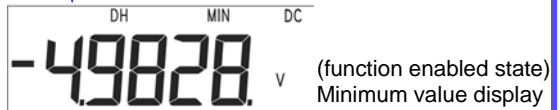

4.8.5 Dual Display Function

This function simultaneously monitors two different measurement parameters (voltage, current, frequency, duty cycle or pulse width) of one signal.

Procedure

1. Press the [DUAL] or [Hz] button to activate dual display.



- (1) Pressing the [DUAL] button selects the Dual Display mode. Pressing it repeatedly changes the display as follows.

Function Selector Position	Primary Display	Secondary Display
	Voltage measurement (V)	Frequency measurement
		Source function display
mV	Voltage measurement (mV)	Frequency measurement
		Source function display
mA	Current measurement (mA)	Frequency measurement
		Source function display

4.8 Special Measurement Functions

- (2) Press the [Hz] button to activate frequency measurement (or duty cycle or pulse width) in the Dual Display mode. Pressing it repeatedly changes the display as follows.

Function Selector Position	Primary Display	Secondary Display
	Frequency	Voltage measurement (V)
	Duty cycle	
	Pulse width	
mV	Frequency	Voltage measurement (mV)
	Duty cycle	
	Pulse width	
mA	Frequency	Current measurement (mA)
	Duty cycle	
	Pulse width	

- When measuring frequency or pulse width, pressing the [RANGE/AUTO] button toggles between auto- and manual ranging.
- When measuring duty cycle or pulse width, holding the [AC/DC] button for one second toggles the trigger slope between  and .

2. To cancel the Dual Display mode
- When pressed [DUAL] button at procedure 1. : Press [DUAL] button again.
 - When pressed [Hz] button at procedure 1. : Hold the [Hz] button for one second.

Display Example

After pressing the **DUAL** buttons



After pressing the **Hz** button

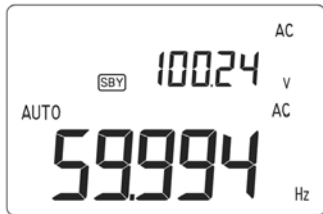

Functions

5

5.1 Auto Power Off Function

The Auto Power Off function is provided to minimize battery consumption.

This function is automatically enabled when the meter is turned on (@OFF appears on the display).

- During operation, if one of the following actions is not performed within a specific period, the meter turns off automatically.
 1. Any key is pressed
 2. The recording function is active
 3. The 1-ms Peak Hold function is active
 4. **OUT** is displayed with Source mode
 5. If the Auto Power Off function has been disabled in the Power-On Options
- To turn power back on after it has been turned off, move the function selector to the **[OFF]** position, wait for one second, then turn it back on.

NOTE

When power is turned off by Auto Power Off, all settings are reset.

When you will be using the meter for a long period, disable Auto Power Off (so that @OFF does not appear on the display)

Disabling Auto Power Off

Timing and disabling of the Auto Power Off function is set in the Power-On Options.

❖ 5.4 "Power-On Options" (76 p.)

To disable the function, set the time to **[OFF m]**.

5.2 Backlight Function

The LCD backlight can be enabled or disabled.

Procedure

1. Hold the [**SHIFT**] button for one second to turn on the LCD backlight.



Once the backlight is turned on, it turns off automatically after a preset time (set by the Backlight Auto-Off function).

2. Hold the [**SHIFT**] button for one second if you want to manually turn off the LCD backlight.

Disabling the Backlight Auto-Off Function

Timing and disabling of the Backlight Auto-Off function are set in the Power-On Options.

❖ 5.4 "Power-On Options" (76 p.)

To disable the function, set the time to [**OFF sec**].

5.3 RS-232C Communication Functions

The meter includes a data transfer function using an RS-232C interface, by which the meter can be connected to a PC to transfer measurement data for collection and storage.

NOTE

To use this function, one of the following optional Communications Packages, consisting of a special cable and software, is required: Model 3856-01 COMMUNICATION PACKAGE (RS-232C), or Model 3856-02 COMMUNICATION PACKAGE (USB).

Transferring Data to a PC

1. The optical-connector end of the communication cable connects to the socket on the back of the meter.

At this time, the "RS-232C INTERFACE" label should face upward.

2. Connect the 9-pin D-sub connector on the cable to an RS-232C interface on the PC. (when using 3856-01)

Connect the USB connector on the cable to a USB interface on the PC. (when using 3856-02)

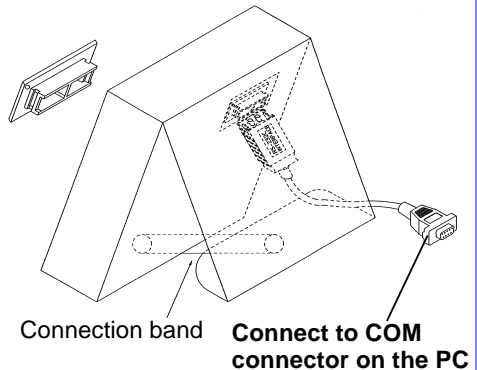

3. If using the 3856-02, install the supplied driver. Run the software to activate data acquisition.

NOTE

- Refer to the instruction manual provided with the 3856-01, 3856-02 for software usage procedures.
- When operating with the case cover folded back, install the supplied connection band to lessen the chance of tipping over.

5.4 Power-On Options

These settings are retained even when power is turned off and the batteries removed.

The various settings are described in the table on the next page.

Setting Procedure

1. Turn the meter off (if on).
2. Hold the [**AC/DC**] button while turning the meter on (set the function selector to any position).
3. Press the [**◀**] or [**▶**] button to select the item you want to set.
4. Press the [**▲**] or [**▼**] button to change the setting.
5. Press the [**Hz**] button to accept your setting.
(The selected item ceases blinking and stays lit)
6. Press the [**SHIFT**] button. All LCD segments appear and progress through the Power-On Options setting displays.



To set multiple items, repeat Steps 3 to 5 above.

NOTE

If you change an item without pressing the [**Hz**] button, or if you hold the [**Hz**] button for more than one second, the selected setting remains unchanged.

Power-On Options

Item	Display	Default (factory setting)	Selection Contents
Echo	Echo	OFF	OFF/ON With ECHO ON, the meter echoes (returns) all the characters whatever it receives.
Data length	DATAb	8 bit	8bit/7bit
Party	PARTY	None	None/odd/EN (even)
Baud Rate	bAud	9600 bps	2400 bps/4800 bps/9600 bps/19200 bps The display shows [Hz] in place of [bps].
Backlight	BL it	30 sec	OFF sec/01 to 99 sec Setting OFF disables the Backlight Auto Off function
Auto power off	AOFF	15 m	OFF m/01 to 99 m • Setting OFF disables the Auto Power-Off function • "m" means "minute".
Refresh hold	rhold	OFF	OFF/100/200/300/400/500/600/700/800/900/1000 Setting OFF enables Data Hold
Beep sound	BEEP	4800 Hz	OFF/600 Hz/1200 Hz/2400 Hz/4800 Hz
Minimum Measurement Frequency	FrEQ	0.5 Hz	0.5 Hz/1 Hz/2 Hz
DCmA% Display	PECnt	4-20 mA	4-20 mA/0-20 mA
Printer	Print	OFF	OFF/ON When turned ON, data for every sample is output to the serial interface. When turned ON,  appears blinking, and other serial communications are disabled.



Applications

6

6.1 Transducer Calibration

Transducers that accept pulse input and provide current output can be calibrated.

Procedure

1. Set the slide switch to the [M/S] position.

2. Set the function selector to the [PULSE] and [DC/~mA] position.

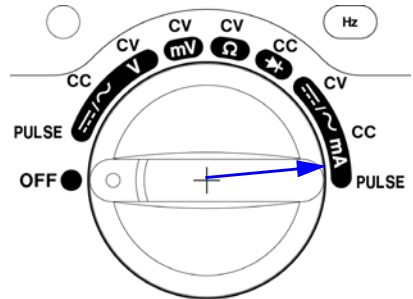

3. Press the [SHIFT] button and confirm that [SHIFT] is displayed on the LCD.
4. Press the [MODE] button, and set the duty cycle, pulse width and frequency.
5. While paying attention to polarity, connect the meter's output terminals to the transducer's input terminals, and the meter's input terminals to the transducer's output.
6. Press the [OUTPUT] button to begin pulse generation. (During the sourcing, [OUT] is displayed on the LCD.)

7. Read the displayed value
Verify that the frequency and current values meet the transducer's specifications.

 8. Change the frequency and observe the current value.
-

6.2 Loop Test

The meter's constant current source function can be used to check 4- to 20-mA measurement devices.

Wiring Preparation

1. Set the slide switch to [M/S] and set the function selector as shown in the illustration.

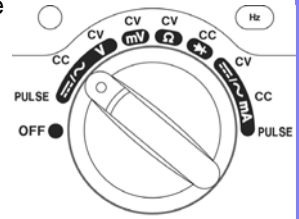

2. Using the voltage measurement function of the meter (see 4.1 (52 p.)), measure the (loop) voltage between the input terminals of the device under test.

Note which terminal has the higher voltage.

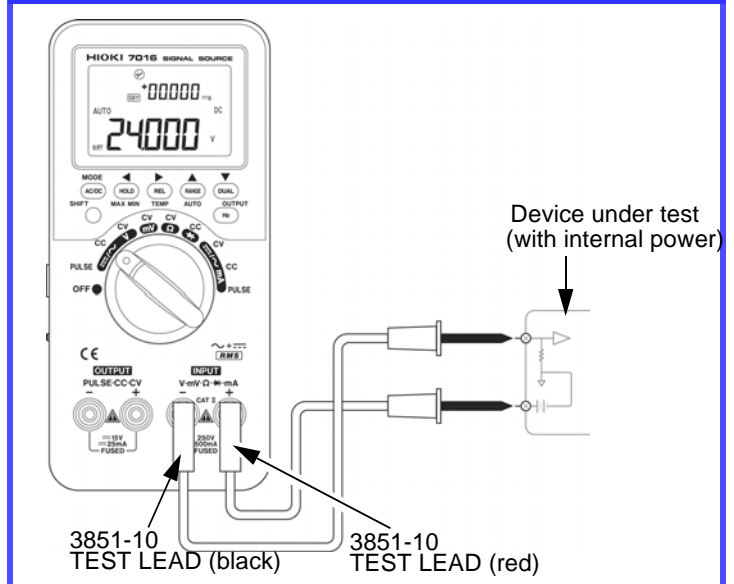

Wiring

1. Connect the black test lead from the negative OUTPUT terminal of the meter to the higher-voltage terminal of the device under test.
2. Connect the yellow test lead from the positive OUTPUT terminal of the meter to the lower-voltage terminal of the device under test.

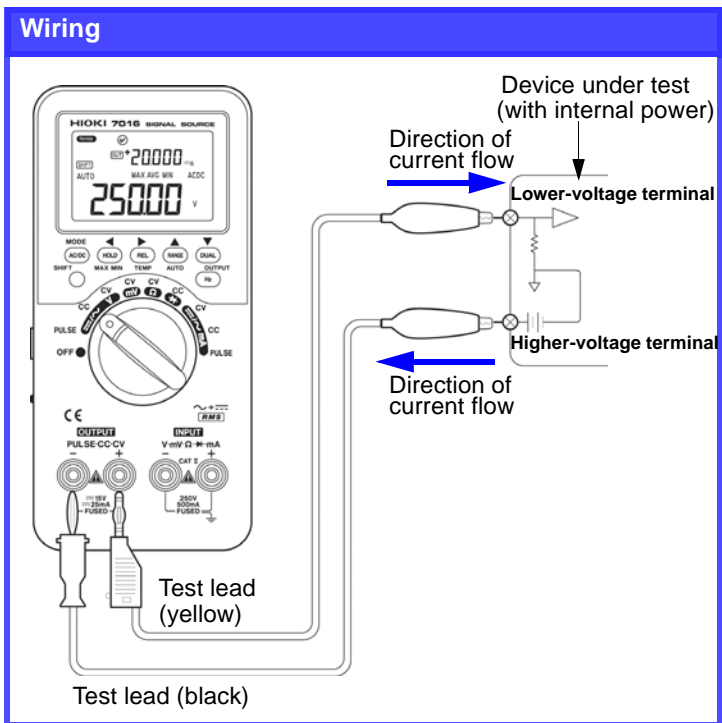

3. Press the [SHIFT] button and confirm that [SHIFT] is displayed on the LCD.

NOTE

Use the supplied red test lead when testing measurement instruments that are not internally powered. The set current will not flow if the yellow test lead is used.

4. Use the cursor buttons [◀/▶/▲/▼] to set the current to be sourced. The setting value should have positive polarity. Press the [OUTPUT] button to output the current.
(During the sourcing, **OUT** is displayed on the LCD.)

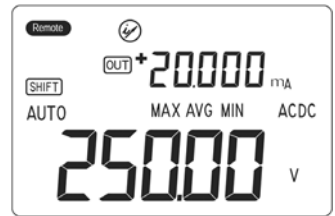



Specifications

7

7.1 Product Specifications

Output method	Bipolar sink/source output
Measurement method	Double integral system
AC Measurement method	True RMS
Functions	DC constant voltage (DCCV) source, DC constant current (DCCC) source, Pulse (PULSE) source, DC voltage (DCV) measurement, AC voltage (ACV) measurement, AC + DC voltage (ACDCV) measurement, DC current (DCA) measurement, AC current (ACA) measurement, AC + DC current (ACDCA) measurement, Resistance (OHM) measurement, Diode testing (DIODE), Continuity testing (CONT), Temperature (TEMP) measurement, Frequency (FREQ) measurement, Duty cycle (DUTY) measurement, Pulse width (WIDTH) measurement
Additional functions	<ul style="list-style-type: none"> • Settable duty cycle, pulse width and amplitude pulse generation • Memory generation (16 memory data settings per range); scan generation (single/continuous) • Ramp generation • AC+DC RMS voltage/current measurement • 1-ms Peak Hold (for voltage/current measurement) • Recording • Data Hold/Refresh Hold • Relative display • 4 - 20 mA current-loop percentage display, 0 - 20 mA percentage display • RS-232C data communications • Power-on options
Switches	Slide switch, Function selector
Range selection	Full auto or manual
Display device	LCD with backlight
Display contents	Two 5-digit numeric digital displays (for source and measurement functions), one large primary display and one small secondary display)
Maximum measurement count	51,000 counts
Polarity indicator	"-" symbol displayed automatically
Auto power off	Settable (0 to 99 minutes in 1-minute intervals)
Low battery indication	Warning on LCD when battery voltage falls below 9 V
Sampling rate	Approx. 3/s (except AC+DC and frequency measurement) Approx. 1/s for AC+DC and frequency measurement Approx. 0.25 - 4/s for duty cycle and pulse width measurement
Temperature characteristic	Add the following except within 23±5°C Source functions : ±(50ppm of setting + 0.5dgt)/°C Measurement functions: ±(measurement accuracy × 0.15)/°C
Noise susceptibility	NMRR >60 dB (50/60 Hz) CMRR >90 dB (50/60 Hz)

7.1 Product Specifications

Over load protection	DCCV, DCCC, PULSE: ± 30 VDC, fuse protected (250VT63 mA fuse) DCV, ACV, ACDCV : 250 VDC/250 Vrms at 10^6 V • Hz maximum voltage-frequency product DCA, ACA, ACDCA : fuse protected (250VF630 mA fuse) OHM, DIODE, CONT, TEMP, FREQ: 250 Vrms at 10^6 V • Hz maximum voltage-frequency product
Maximum rated voltage and current	<ul style="list-style-type: none"> • Maximum output voltage and current : ± 15 V, ± 25 mA • Maximum input voltage and current : 250 V, 500 mA • Maximum voltage to earth of the input terminal: 250 V
Withstand voltage	<ul style="list-style-type: none"> • Between case and combined power supply terminals: 510-Vrms 50/60-Hz sine wave for one minute • Between case and combined output terminals: 510-Vrms 50/60-Hz sine wave for one minute • Between combined input terminals and combined output terminals: 510-Vrms 50/60-Hz sine wave for one minute • Between case and combined input terminals: 2.3-kVrms 50/60-Hz sine wave for one minute • Between combined power supply terminals and combined input terminals: 2.3-kVrms 50/60-Hz sine wave for one minute • Between combined output terminals and combined input terminals: 2.3-kVrms 50/60-Hz sine wave for one minute
Operating temperature & humidity	0 to 40°C, 0 to 80%RH (non-condensation) However, above 30°C, humidity is derated to 50% RH at 40°C
Storage temperature & humidity	-20 to 60°C, 0 to 80%RH (non-condensation, w/o batteries)
Operating location	Indoors, below 2000m ASL
Period of guaranteed accuracy	1 year
Power supply	<ul style="list-style-type: none"> • Eight 1.5V AA-size (LR6) alkaline batteries, or Eight 1.2V NiMH batteries • AC adapter (Model No SA-141A0F-11 supplied) Rated mains voltage and frequency 100 to 250 VAC @ 47 to 63 Hz (Voltage fluctuations of $\pm 10\%$ from the rated supply voltage are taken into account.)
Rated power consumption	3.5 VA typical (@25 mA CC, with maximum load) 0.6 VA typical (measurement only)
Maximum rated power consumption	5 VA
Continuous operation	Approx. 20 hours measurement only, 4 hours both sourcing and measuring (with supplied NiMH batteries, new, with full charge)
Charging time	Approx. 8 hours (at 0 to 30°C ambient temperature)
Dimensions	Approx. 90W \times 192H \times 54D mm
Mass	Approx. 735 g (instrument only)
Accessories	AC adapter SA-141A0F-11 (with power cord) 1 Battery pack (Ni-MH battery) 8 (four 2-cell packs) Carrying case 1 3851-10 TEST LEAD (one each red and black, for Input terminal) 1 Test leads (one each red and black, for Output terminal) 1 Test lead (Yellow, with 15V zener diode) 1 Alligator clips (one each red and black, for Model 3851-10) 1 Instruction manuals 1 Operation guide 1
Replacement parts	Fuses: 250VT63mAL, 250VF630mAH

Options	3856-01 COMMUNICATION PACKAGE (RS-232C) 3856-02 COMMUNICATION PACKAGE (USB) 9180 SHEATH TYPE TEMPERATURE PROBE 9181 SURFACE TEMPERATURE PROBE 9182 SHEATH TYPE TEMPERATURE PROBE (Class 1) 9183 SHEATH TYPE TEMPERATURE PROBE (Class 1) 9472 SHEATH TYPE TEMPERATURE PROBE (Class 1) 9473 SHEATH TYPE TEMPERATURE PROBE (Class 1) 9474 SHEATH TYPE TEMPERATURE PROBE (Class 1) 9475 SHEATH TYPE TEMPERATURE PROBE (Class 1) 9476 SURFACE TEMPERATURE PROBE
Applicable standards	Safety : EN61010-1:2001 EN61010-031:2002 Pollution degree 2 Measurement category II (anticipated transient overvoltage 2,500V) EMC : EN61326:1997+A1:1998+A2:2001+A3:2003 EN61000-3-2:2000 EN61000-3-3:1995+A1:2001

7.2 Accuracy

7.2.1 Source Range and Accuracy

Accuracy is specified at $23 \pm 5^\circ\text{C}$, and 80%RH or less, after at least five minutes warm-up.

DC constant voltage (DCCV) source Function

Range	Output Range	Resolution	Accuracy	Remarks
1.5000 V	0 to ± 1.5000 V	0.1 mV	$\pm(0.03\%$ of setting+3 dgt.)	Sink/source output At least $\pm 25\text{mA}$ max. output
15.000 V	0 to ± 15.000 V	1 mV		

- Load regulation = 0.012 mV/mA
- Maximum applied voltage = ± 30 VDC

DC constant current (DCCC) source Function

Range	Output Range	Resolution	Accuracy	Remarks
25.000 mA	0 to ± 25.000 mA	1 μA	$\pm(0.03\%$ of setting+5 dgt.)	Sink/source output At least ± 12 V output

- Load regulation = 1 $\mu\text{A/V}$
- Maximum applied voltage = ± 30 VDC

Pulse (PULSE) source Function

Setting	Output Range	Resolution	Accuracy
Frequency	0.5, 1, 2, 5, 10, 15, 20, 25, 30, 40, 50, 60, 75, 80, 100, 120, 150, 200, 240, 300, 400, 480, 600, 800, 1200, 1600, 2400, 4800 Hz	-	$\pm(0.005\%$ of setting+0.01 Hz)
Duty	0.39% ~ 99.60 %	0.390625%	$\pm(0.01\%$ of setting+0.2 %) However, at 1 kHz and above, add $\pm 0.1\%$ /kHz of setting.
Pulse width	$(0.39\% \sim 99.60\%) \times 1/\text{frequency}$	$1/(256 \times \text{Frequency})$	$\pm(0.01\%$ of setting+0.3 ms)
Output voltage	5 V, 12 V	-	$\pm(2\%$ of setting+0.2 V)
	± 5 V, ± 12 V	-	$\pm(2\%$ of setting+0.4 V)

- Duty cycle and pulse width must be set with at least 50 μs positive pulse width.
- Duty cycle and pulse width output voltage accuracy specification presumes at least 50 μs positive pulse width.
- Maximum applied voltage is ± 30 VDC.

7.2.2 Measurement Range and Accuracy

Accuracy is specified at $23 \pm 5^{\circ}\text{C}$, and 80%RH or less, after at least five minutes warm-up.

DC voltage measurement (DCV) function

Range	Measurement Range	Resolution	Accuracy
50 mV*1	0 mV to ± 51.000 mV	1 μV	$\pm(0.05\%$ of rdg. +5 dgt.)
500 mV	0 mV to ± 510.00 mV	10 μV	$\pm(0.03\%$ of rdg. +5 dgt.)
5 V	0 mV to ± 5.1000 V	0.1 mV	
50 V	0 mV to ± 51.000 V	1 mV	
250 V	0 mV to ± 250.00 V	10 mV	

- Input impedance : 50 mV and 500 mV ranges: 1000 M Ω
: 5 V, 50 V and 250 V ranges: 10 M Ω

- Overvoltage protection : 250 Vrms

- Upper limit voltage-frequency product : 10^6 V \cdot Hz

*1: When measuring REL after shorting input terminals before measurement.
Accuracy when not measuring REL is $\pm(0.05\%$ of setting+50 dgt.).

AC voltage measurement (ACV) function

Range	Measurement Range	Resolution	Accuracy	
			45 Hz to 5 kHz	5 kHz to 20 kHz
50 mV	0 mV to 51.000 mV	1 μV	$\pm(0.7\%$ of rdg.+40 dgt.)	$\pm(1.5\%$ of rdg.+40 dgt.)
500 mV	0 mV to 510.00 mV	10 μV	$\pm(0.7\%$ of rdg.+20 dgt.)	$\pm(1.5\%$ of rdg.+20 dgt.)
5 V	0 mV to 5.1000 V	0.1 mV		
50 V	0 mV to 51.000 V	1 mV		
250 V	0 mV to 250.00 V	10 mV		

- Accuracy specified for 5% or more from the edges of range.

- Input impedance : 50 mV and 500 mV ranges : 1000 M Ω
: 5 V, 50 V and 250 V ranges : 10 M Ω /(100pF or less)

- Overvoltage protection : 250 Vrms

- Crest factor : 3 or less

- Upper limit voltage-frequency product : 10^6 V \cdot Hz

AC + DC voltage measurement (ACDCV) function

Range	Measurement Range	Resolution	Accuracy	
			45 Hz to 5 kHz	5 kHz to 20 kHz
50 mV	0 mV to 51.000 mV	1 μ V	$\pm(0.8\%$ of rdg.+70 dgt.)	$\pm(1.6\%$ of rdg.+70 dgt.)
500 mV	0 mV to 510.00 mV	10 μ V	$\pm(0.8\%$ of rdg.+25 dgt.)	$\pm(1.6\%$ of rdg.+25 dgt.)
5 V	0 mV to 5.1000 V	0.1 mV		
50 V	0 mV to 51.000 V	1 mV		
250 V	0 mV to 250.00 V	10 mV		

- Accuracy specified for 5% or more from the edges of range.
- Input impedance : 50 mV and 500 mV ranges : 1000 M Ω
: 5 V, 50 V and 250 V ranges : 10 M Ω /(100pF or less)
- Overvoltage protection : 250 Vrms
- Crest factor : 3 or less
- Upper limit voltage-frequency product : 10^6 V•Hz

DC current measurement (DCA) function

Range	Measurement Range	Resolution	Accuracy	Maximum voltage/shunt resistance
50 mA ^{*1}	0 mA to \pm 51.000 mA	1 μ A	$\pm(0.03\%$ of rdg.+5 dgt.)	0.06 V (1 Ω)
500 mA ^{*1}	0 mA to \pm 510.00 mA	10 μ A		0.6 V (1 Ω)

Overcurrent protection : fast-blow fuse (630 mA @250 V)

*1: When measuring REL after opening input terminals before measurement, or for "0 mA" input. Accuracy when not measuring REL is $\pm(0.03\%$ of rdg. + 25 dgt.)

AC current measurement (ACA) function

Range	Measurement Range	Resolution	Accuracy (45 Hz to 2 kHz)	Maximum voltage/shunt resistance
50 mA	0 mA to 51.000 mA	1 μ A	$\pm(0.6\%$ of rdg.+20 dgt.)	0.06 V (1 Ω)
500 mA	0 mA to 510.00 mA	10 μ A		0.6 V (1 Ω)

- Accuracy specified for 5% or more from the edges of range.
- Overcurrent protection : fast-blow fuse (250 V@630 mA)
- Crest factor : 3 or less

AC + DC current measurement (ACDCA) function

Range	Measurement Range	Resolution	Accuracy (45Hz to 2kHz)	Maximum voltage/shunt resistance
50 mA	0 mA to 51.000 mA	1 μ A	$\pm(0.7\%$ of rdg.+40 dgt.)	0.06 V (1 Ω)
500 mA	0 mA to 510.00 mA	10 μ A		0.6 V (1 Ω)

- Accuracy specified for 5% or more from the edges of range.
- Overcurrent protection : fast-blow fuse (250 V@630 mA)
- Crest factor : 3 or less

1-ms Peak Hold voltage measurement (V) function

Range	Measurement Range	Resolution	Accuracy
50 mV	0 mV to \pm 51.000 mV	1 μ V	$\pm(2\%$ of rdg. + 400 dgt.)
500 mV	0mV to \pm 510.00 mV	10 μ V	
5 V	0 mV to \pm 5.1000 V	0.1 mV	
50 V	0 mV to \pm 51.000 V	1 mV	
250 V	0 mV to \pm 250.00 V	10 mV	

- Measurement accuracy specifications apply to signals with transition times exceeding 1 ms.
- Input impedance : 50 mV and 500 mV ranges : 1000 M Ω
: 5 V, 50 V and 250 V ranges: 10 M Ω
- Overcurrent protection : 250 Vrms

1-ms Peak Hold current measurement (A) function

Range	Measurement Range	Resolution	Accuracy	Maximum voltage/shunt resistance
50 mA	0 mV to \pm 51.000 mA	1 μ V	$\pm(2\%$ of rdg.+400 dgt.)	0.06 V (1 Ω)
500 mA	0 mV to \pm 510.00 mA	10 μ V		0.6 V (1 Ω)

- Measurement accuracy specifications apply to signals with transition times exceeding 1 ms.
- Overcurrent protection : fast-blow fuse (250 V@630 mA)

Resistance measurement (OHM) function

Range	Measurement Range	Resolution	Accuracy	Measurement current	Open-Circuit Terminals
500 Ω^*1	0 Ω to 510.00 Ω	0.01 Ω	$\pm(0.15\%$ of rdg.+8 dgt.)	0.45 mA	<+4.8 VDC
5 k Ω^*1	0 Ω to 5.1000 k Ω	0.1 Ω	$\pm(0.15\%$ of rdg.+5 dgt.)	45 μ A	
50 k Ω	0 Ω to 51.000 k Ω	1 Ω		4.5 μ A	
500 k Ω	0 Ω to 510.00 k Ω	10 Ω		450 nA	
5 M Ω	0 Ω to 5.1000 M Ω	0.1 k Ω		45 nA	
50 M Ω	0 Ω to 51.000 M Ω	1 k Ω	$\pm(1\%$ of rdg.+8 dgt.)	45 nA	

*1: Measuring REL to short-circuited probes

- If measured value is 1000 dgt. or less, the beeper sounds (on/off settable).
- Accuracy of 50 M Ω range is specified at 60%RH or less.
- Overcurrent protection : 250 Vrms

Diode test (DIODE) function

Range	Resolution	Accuracy	Measurement current	Open-Circuit Terminals
Diode	0.1 mV	$\pm(0.05\%$ of rdg.+5 dgt.)	Approx. 0.45 mA	<+4.8 VDC

Overcurrent protection : 250 Vrms

Continuity test (CONT) function

Range	Resolution	Accuracy	Measurement current	Open-Circuit Terminals
Diode	-	Beeper sounds at about 50 mV or less	Approx. 0.45 mA	<+4.8 VDC

Overcurrent protection : 250 Vrms

Temperature measurement (K Thermocouple) (TEMP) function

Range	Measurement Range	Resolution	Accuracy
$^{\circ}$ C	-40 to 1372 $^{\circ}$ C	0.1 $^{\circ}$ C	$\pm(0.3\%$ of rdg.+3 $^{\circ}$ C)

- The above accuracy does not include thermocouple accuracy.
- Overcurrent protection : 250 Vrms

Frequency Measurement (Voltage measurement function) (FREQ) function

Range	Measurement Range	Resolution	Accuracy
100 Hz	0.500 Hz to 99.999 Hz	0.001 Hz	±(0.02% of rdg.+3 dgt.)
1 kHz	0.50Hz to 999.99 kHz	0.01 Hz	
10 kHz	0.5Hz to 9.9999 kHz	0.1 Hz	
100 kHz	1 Hz to 99.999 kHz	1 Hz	
200 kHz	10 Hz to 199.99 kHz	10 Hz	

- Minimum input frequency: 0.5 Hz (settable Power-On Option)
- Overcurrent protection : 250 Vrms

(Voltage Measurement Sensitivity)

Input range	Minimum Sensitivity (rms sine wave)		Trigger level (DC coupling)	
	1 Hz to 100 kHz	>100 kHz	< 20 kHz	20 kHz to 200 kHz
50 mV	15 mV	25 mV	20 mV	30 mV
500 mV	35 mV	200 mV	50 mV	80 mV
5 V	0.3 V	0.5 V	0.5 V	0.8 V
50 V	3 V	5 V	5 V	8 V
250 V	30 V	-	60 V	-

Accuracy of duty cycle and pulse width measurement specifications presume 5 V pulses in the 5 V DC range.

DUTY CYCLE

Measurement range : 0.1% to 99.9 % (at DC coupling)
5% to 95% (at AC coupling)

Accuracy : < ±(0.3% / kHz+0.3% of f.s.)

PULSE WIDTH

Measurement range : 0.1 ms to 1999 ms

Accuracy : < ±(0.2% of rdg.+3 dgt.)

The specified measurement range is determined by the signal frequency when the pulse width is greater than 10 μs.

(Current Measurement Sensitivity)

Input range	Minimum Sensitivity (rms sine wave)
	30 Hz to 20 kHz
50 mA	2.5 mA
500 mA	25 mA



Maintenance and Service

8

When sending the instrument for repair, remove the batteries and pack carefully to prevent damage in transit. Include cushioning material so the instrument cannot move within the package. Be sure to include details of the problem. Hioki cannot be responsible for damage that occurs during shipment.

8.1 Replacing the Batteries



!WARNING

- To avoid electric shock when replacing the batteries, first disconnect the test leads from the object to be measured.
- Do not mix old and new batteries, or different types of batteries. Also, be careful to observe battery polarity during installation. Otherwise, poor performance or damage from battery leakage could result.

While operating with batteries, the  indicator appears on the display when battery voltage get low. In that case, the batteries can be replaced by the following procedure.

Procedure

1. Press the **[OUTPUT]** button to turn off output, if active. (Verify that **[OUT]** is no longer displayed.)
2. Set the function selector to the **[OFF]** position.
3. Using a Philips screwdriver, loosen the screw affixing the battery compartment cover, remove the cover, and replace the batteries.
4. Replace the battery compartment cover and tighten the screw.

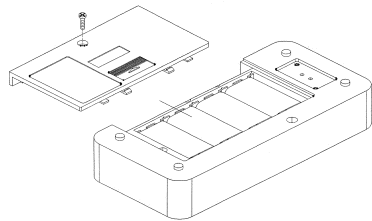

!CAUTION

When the  indicator appears on the LCD, continuing operation with power on may result in the internal controls malfunctioning or unintended output may occur, which could damage the meter or the device under test.

Therefore, when  appears, turn the power off as soon as possible.

NOTE

- To avoid corrosion from battery leakage, remove the batteries from the instrument if it is to be stored for a long time.
- The supplied battery pack contains NiMH batteries. Continuing to operate the meter when the  indicator appears can over-discharge the batteries and shorten their useful life.
- Use the supplied battery packs or common AA-size (LR6) alkaline batteries.
- Do not mix alkaline batteries and the supplied NiMH batteries.
- Use four pairs of the supplied batteries together as a set.
- When replacing the supplied batteries, always replace all four pairs as a set.
- Do not charge the supplied batteries with a charger other than the one provided.
- Do not disassemble the supplied battery packs.
- The batteries will gradually lose their charge by self-discharge. Always charge the batteries before using the first time.

8.2 Replacing the Fuses



!WARNING

- To avoid electric shock, turn off the function selector and disconnect the batteries and AC adapter before replacing the fuse.
- Replace the fuse only with one of the specified characteristics and voltage and current ratings. Using a non-specified fuse or shorting the fuse holder may cause a life-threatening hazard.
Fuse type: 250VF63mA, 250VF630mA

Procedure

1. Set the function selector to [OFF], and disconnect all cables from the meter.
2. Using a Philips screwdriver, remove the screws and lift off the front of the case.
3. Carefully remove the blown fuse from the fuse holder.
4. Replace the fuse with a new one.

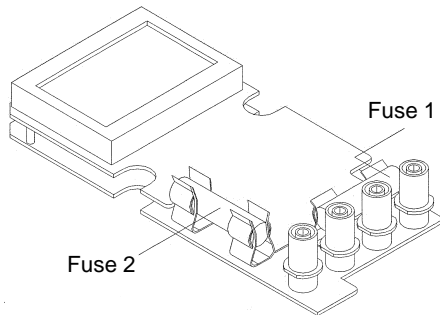

Fuse	Voltage	Current	Size	Type
1	250 V	630 mA	5×20 mm	Fast-blow type
2	250 V	63 mA	5×20 mm	Slow-blow type

5. Verify that both the function selector on the front of the case and on the circuit board is set to the [OFF] position, and reassemble the case.
6. Tighten the screws

8.3 Before returning for repair

If damage is suspected, check the following before contacting your dealer or Hioki representative.

Symptom	Check Item	Remedy	Reference
Nothing appears on the display when the slide switch is set to [M] or [M/S] and the function selector is set to a position other than [OFF]	<ul style="list-style-type: none"> Are the batteries installed? Are the batteries depleted? 	Install new batteries.	❖ 8.1 (96 p.)
	<ul style="list-style-type: none"> Are the supplied Battery pack (Ni-MH batteries) charged? 	Charge the supplied NiMH batteries.	❖ 2.2 (20 p.)
	<ul style="list-style-type: none"> Is the AC Adapter connected? 	Connect the AC Adapter.	❖ 2.1 (19 p.)
	<ul style="list-style-type: none"> Is the fuse installed? 	Install (replace) the fuse.	❖ 8.2 (98 p.)
	<ul style="list-style-type: none"> Is the fuse blown? 		
The batteries do not charge when the slide switch is set to [CHARGE].	<ul style="list-style-type: none"> Is the AC Adapter connected? 	Connect the AC Adapter.	❖ 2.1 (19 p.)
	<ul style="list-style-type: none"> Is the fuse installed? 	Install (replace) the fuse.	❖ 8.2 (98 p.)
	<ul style="list-style-type: none"> Is the fuse blown? 		
Source functions do not work.	<ul style="list-style-type: none"> Is the slide switch set to the [M/S] position? 	Set it to the [M/S] position.	❖ 3.1 (32 p.)
	<ul style="list-style-type: none"> Is the fuse installed? 	Install (replace) the fuse.	❖ 8.2 (98 p.)
	<ul style="list-style-type: none"> Is the fuse blown? 		

8.4 Discarding the Instrument

The meter is powered by batteries or the AC Adapter. Before disposing of the meter, remove the batteries and dispose of them according to the prescribed procedure.

- ❖ 8.1 "Replacing the Batteries" (page 96)

NOTE

When disposing of this instrument, remove the batteries and take them to a Nickel Cadmium battery recycling center or dispose of them according to their type in the prescribed manner and in the proper location. If there are local regulations concerning the disposal of Nickel Cadmium batteries, dispose of the batteries in accordance with those regulations.

8.5 Cleaning

- To clean the instrument, wipe it gently with a soft cloth moistened with water or mild detergent. Never use solvents such as benzene, alcohol, acetone, ether, ketones, thinners or gasoline, as they can deform and discolor the case.
- Wipe the LCD gently with a soft, dry cloth.

HIOKI

DECLARATION OF CONFORMITY

Manufacturer's Name: HIOKI E.E. CORPORATION
Manufacturer's Address: 81 Koizumi, Ueda, Nagano 386-1192, Japan
Product Name: SIGNAL SOURCE
Model Number: 7016
Accessory: 3851-10 TEST LEAD
Options: 3856-01 COMMUNICATION PACKAGE
(RS-232C)
3856-02 COMMUNICATION PACKAGE (USB)
9180 SHEATH TYPE TEMPERATURE PROBE
9181 SURFACE TEMPERATURE PROBE
9182 SHEATH TYPE TEMPERATURE PROBE
9183 SHEATH TYPE TEMPERATURE PROBE
9472 SHEATH TYPE TEMPERATURE PROBE
9473 SHEATH TYPE TEMPERATURE PROBE
9474 SHEATH TYPE TEMPERATURE PROBE
9475 SHEATH TYPE TEMPERATURE PROBE
9476 SURFACE TYPE TEMPERATURE PROBE

The above mentioned products conform to the following product specifications:

Safety: EN61010-1:2001
EN61010-031:2002
EMC: EN61326:1997+A1:1998+A2:2001+A3:2003
Class B equipment
Minimum immunity test requirement
Portable test, measuring and monitoring
equipment used in low-voltage distribution
systems
EN61000-3-2:2000
EN61000-3-3:1995+A1:2001

Supplementary Information:

The product herewith complies with the requirements of the Low Voltage Directive 73/23/EEC and the EMC Directive 89/336/EEC.

HIOKI E.E. CORPORATION

29 September 2006



Tatsuyoshi Yoshiike

President

7016A999-02

HIOKI 7016 SIGNAL SOURCE
Instruction Manual

Publication date: September 2006 Revised edition 2
Edited and published by HIOKI E.E. CORPORATION
Technical Support Section

All inquiries to International Sales and Marketing Department
81 Koizumi, Ueda, Nagano, 386-1192, Japan
TEL: +81-268-28-0562 / FAX: +81-268-28-0568
E-mail: os-com@hioki.co.jp
URL <http://www.hioki.co.jp/>

Printed in Japan 7016A981-02

-
-
- All reasonable care has been taken in the production of this manual, but if you find any points which are unclear or in error, please contact your supplier or the International Sales and Marketing Department at HIOKI headquarters.
 - In the interests of product development, the contents of this manual are subject to revision without prior notice.
 - Unauthorized reproduction or copying of this manual is prohibited.
-
-

HIOKI

HIOKI E. E. CORPORATION

HEAD OFFICE

81 Koizumi, Ueda, Nagano 386-1192, Japan

TEL +81-268-28-0562 / FAX +81-268-28-0568

E-mail: os-com@hioki.co.jp / URL <http://www.hioki.co.jp/>

HIOKI USA CORPORATION

6 Corporate Drive, Cranbury, NJ 08512, USA

TEL +1-609-409-9109 / FAX +1-609-409-9108

7016A981-02 06-09H



Printed on recycled paper

T  **USA**
Equipment
.NETTM
1-877-742-TEST (8378)